

FEATURES

- Measures active, reactive, and apparent energy; sampled waveform; current and voltage rms
- Provides a second current input for neutral current measurement
- Less than 0.1% error in active and reactive energy measurements over a dynamic range of 3000:1
- Less than 0.2% error in instantaneous IRMS measurement over a dynamic range of 1000:1
- Provides apparent energy measurement and instantaneous power readings
- 1.23 kHz bandwidth operation
- Flexible PGA gain stage (up to $\times 22$)
- Includes internal integrators for use with Rogowski coil sensors
- SPI, I²C, or UART communication

GENERAL DESCRIPTION

The ADE7953 is a high accuracy electrical energy measurement IC intended for single phase applications. It measures line voltage and current and calculates active, reactive, and apparent energy, as well as instantaneous rms voltage and current.

The device incorporates three Σ - Δ ADCs with a high accuracy energy measurement core. The second input channel simultaneously measures neutral current and enables tamper detection and neutral current billing. The additional channel incorporates a complete signal path that allows a full range of measurements. Each input channel supports independent and flexible gain stages, making the device suitable for use with a variety of current sensors such as current transformers (CTs) and low value shunt resistors. Two on-chip integrators facilitate the use of Rogowski coil sensors.

The ADE7953 provides access to on-chip meter registers via a variety of communication interfaces including SPI, I²C, and UART. Two configurable low jitter pulse output pins provide outputs that are proportional to active, reactive, or apparent energy, as well as current and voltage rms. A full range of power quality information such as overcurrent, overvoltage, peak, and sag detection are accessible via the external IRQ pin. Independent active, reactive, and apparent no-load detections are included to prevent “meter creep.” Dedicated reverse power (REVP), zero-crossing voltage (ZX), and zero-crossing current (ZX_I) pins are also provided. The ADE7953 energy metering IC operates from a 3.3 V supply voltage and is available in a 28-lead LFCSP package.

FUNCTIONAL BLOCK DIAGRAM

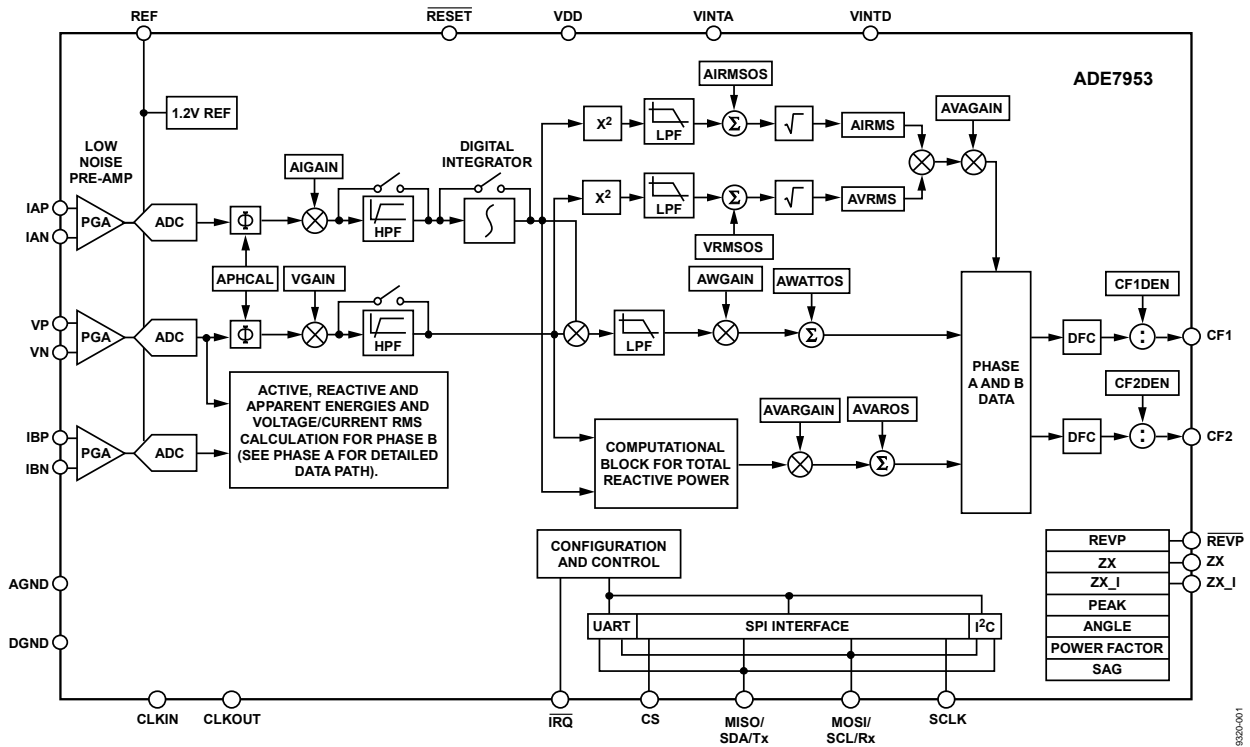

Figure 1.

Rev. A

Information furnished by Analog Devices is believed to be accurate and reliable. However, no responsibility is assumed by Analog Devices for its use, nor for any infringements of patents or other rights of third parties that may result from its use. Specifications subject to change without notice. No license is granted by implication or otherwise under any patent or patent rights of Analog Devices. Trademarks and registered trademarks are the property of their respective owners.

TABLE OF CONTENTS

| | | | |
|--|----|---|----|
| Features | 1 | Period Measurement | 36 |
| General Description | 1 | Instantaneous Powers and Waveform Sampling | 37 |
| Functional Block Diagram | 1 | Power Factor..... | 38 |
| Revision History | 3 | Using the Line Cycle Accumulation Mode to Determine the | |
| Specifications..... | 4 | Power Factor | 38 |
| Timing Characteristics | 6 | Power Factor with No-Load Detection | 38 |
| Absolute Maximum Ratings..... | 8 | Angle Measurement | 39 |
| ESD Caution..... | 8 | No-Load Detection | 40 |
| Pin Configuration and Function Descriptions..... | 9 | Setting the No-Load Thresholds | 40 |
| Typical Performance Characteristics | 11 | Active Energy No-Load Detection..... | 40 |
| Test Circuit | 16 | Reactive Energy No-Load Detection..... | 41 |
| Terminology | 17 | Apparent Energy No-Load Detection | 41 |
| ADE7953 Power-Up Procedure..... | 18 | Zero-Crossing Detection..... | 43 |
| Required Register setting | 18 | Zero-Crossing Output Pins..... | 43 |
| Theory of Operation | 19 | Zero-Crossing Interrupts | 43 |
| Analog Inputs..... | 19 | Zero-Crossing Timeout..... | 44 |
| Analog-to-Digital Conversion..... | 19 | Zero-Crossing Threshold..... | 44 |
| Current Channel ADCs | 21 | Voltage Sag Detection | 45 |
| Voltage Channel ADC | 21 | Setting the SAGCYC Register..... | 45 |
| Reference Circuit..... | 22 | Setting the SAGLVL Register..... | 45 |
| Root Mean Square Measurement | 23 | Voltage Sag Interrupt | 45 |
| Current Channel RMS Calculation..... | 23 | Peak Detection..... | 46 |
| Voltage Channel RMS Calculation..... | 23 | Indication of Power Direction | 47 |
| Active Power Calculation | 24 | Reverse Power | 47 |
| Sign of Active Power Calculation | 24 | Sign Indication..... | 47 |
| Active Energy Calculation..... | 25 | Overcurrent and Overvoltage Detection..... | 48 |
| Active Energy Accumulation Modes..... | 27 | Setting the OVLVL and OILVL Registers | 48 |
| Reactive Power Calculation..... | 28 | Overvoltage and Overcurrent Interrupts..... | 48 |
| Sign of Reactive Power Calculation | 28 | Alternative Output Functions..... | 49 |
| Reactive Energy Calculation | 29 | ADE7953 Interrupts..... | 50 |
| Reactive Energy Accumulation Modes | 30 | Primary Interrupts (Voltage Channel and Current Channel | |
| Apparent Power Calculation | 31 | A)..... | 50 |
| Apparent Energy Calculation | 31 | Current Channel B Interrupts | 50 |
| Ampere-Hour Accumulation..... | 32 | Communicating with the ADE7953 | 51 |
| Energy-to-Frequency Conversion..... | 33 | Communication Autodetection | 51 |
| Pulse Output Characteristics | 33 | Locking the Communication Interface | 51 |
| Energy Calibration | 34 | SPI Interface | 52 |
| Gain Calibration | 34 | I ² C Interface | 53 |
| Phase Calibration | 34 | UART Interface..... | 55 |
| Offset Calibration..... | 35 | Communication Verification and Security..... | 57 |

Write Protection57
 Communication Verification.....57
 Checksum Register58
 ADE7953 Registers60

ADE7953 Register Descriptions62
 Outline Dimensions.....68
 Ordering Guide68

REVISION HISTORY

11/11—Rev. 0 to Rev. A

Changes to Figure 1.....1
 Changes to Table 13
 Changes to Absolute Maximum Ratings Section.....8
 Changes to Table 59
 Replaced Typical Performance Characteristics Section.....11
 Changes to Figure 3516
 Added ADE7953 Power-Up Procedure Section.....18
 Changes to Voltage Channel Section.....19
 Changes to Current Channel RMS Calculation Section and
 Voltage Channel RMS Calculation Section23
 Changes to Active Power Calculation Section24
 Changes to Active Energy Integration Time Under Steady
 Load Section.....25

Changes to Reactive Power Calculation Section28
 Changes to Reactive Energy Integration Time Under Steady
 Load Section29
 Changes to Figure 6547
 Changes to Write Protection Section57
 Replaced Checksum Register Section and added Figure 75 and
 Figure 76.....58
 Changes to Table 1259
 Changes to Table 1460
 Changes to Table 1561
 Replaced Interrupt Enable Section and Interrupt Status
 Registers Section66

2/11—Revision 0: Initial Version

SPECIFICATIONS

VDD = 3.3 V ± 10%, AGND = DGND = 0 V, on-chip reference, CLKIN = 3.58 MHz, T_{MIN} to T_{MAX} = -40°C to +85°C, Register Address 0x120 set to 0x30, unless otherwise noted.

Table 1.

| Parameter | Min | Typ | Max | Unit | Test Conditions/Comments |
|---|-----|------|-------|---------|---|
| PHASE ERROR BETWEEN CHANNELS | | | | | Line frequency = 45 Hz to 65 Hz, HPF on |
| Power Factor = 0.8 Capacitive | | | ±0.05 | Degrees | Phase lead 37° |
| Power Factor = 0.5 Inductive | | | ±0.05 | Degrees | Phase lag 60° |
| ACTIVE ENERGY MEASUREMENT | | | | | |
| Active Energy Measurement Error (Current Channel A) | | 0.1 | | % | Over a dynamic range of 3000:1, PGA = 1, PGA = 22, integrator off |
| Active Energy Measurement Error (Current Channel B) | | 0.1 | | % | Over a dynamic range of 1000:1, PGA = 1, PGA = 16, integrator off |
| AC Power Supply Rejection | | | | | VDD = 3.3 V ± 120 mV rms, 100 Hz |
| Output Frequency Variation | | 0.01 | | % | |
| DC Power Supply Rejection | | | | | VDD = 3.3 V ± 330 mV dc |
| Output Frequency Variation | | 0.01 | | % | |
| Active Energy Measurement Bandwidth | | 1.23 | | kHz | -3 db |
| REACTIVE ENERGY MEASUREMENT | | | | | |
| Reactive Energy Measurement Error (Current Channel A) | | 0.1 | | % | Over a dynamic range of 3000:1, PGA = 1, PGA = 22, integrator off |
| Reactive Energy Measurement Error (Current Channel B) | | 0.1 | | % | Over a dynamic range of 1000:1, PGA = 1, PGA = 16, integrator off |
| AC Power Supply Rejection | | | | | VDD = 3.3 V ± 120 mV rms, 100 Hz |
| Output Frequency Variation | | 0.01 | | % | |
| DC Power Supply Rejection | | | | | VDD = 3.3 V ± 330 mV dc |
| Output Frequency Variation | | 0.01 | | % | |
| Reactive Energy Measurement Bandwidth | | 1.23 | | kHz | -3 db |
| RMS MEASUREMENT | | | | | |
| IRMS and VRMS Measurement Bandwidth | | 1.23 | | kHz | |
| IRMS (Current Channel A) Measurement Error | | 0.2 | | % | Over a dynamic range of 1000:1, PGA = 1, PGA = 22, integrator off |
| IRMS (Current Channel B) and VRMS Measurement Error | | 0.2 | | % | Over a dynamic range of 500:1, PGA = 1, PGA = 16, integrator off |
| ANALOG INPUTS | | | | | |
| Maximum Signal Levels | | | ±500 | mV peak | Differential inputs: IAP to IAN, IBP to IBN |
| | | | ±500 | mV peak | Single-ended input: VP to VN, IBP to IBN |
| | | | ±250 | mV peak | Single-ended input: IAP to IAN |
| Input Impedance (DC) | | | | | |
| IAP Pin | 50 | | | MΩ | |
| IAN Pin | 50 | | | MΩ | |
| IBP, IBN, VP, VN Pins | 540 | | | kΩ | |
| ADC Offset Error | | | | | Uncalibrated error (see the Terminology section) |
| Current Channel B, Voltage Channel | | 0 | ±10 | mV | |
| Current Channel A | | | -12 | mV | PGA = 1 |
| | | | -1 | mV | PGA = 16, PGA = 22 |
| Gain Error | | | | | External 1.2 V reference |
| Current Channel A | | ±3 | | % | |
| Current Channel B | | ±3 | | % | |
| Voltage Channel | | ±3 | | % | |

| Parameter | Min | Typ | Max | Unit | Test Conditions/Comments |
|--|------|-------|------|------------|---|
| ANALOG PERFORMANCE | | | | | |
| Signal-to-Noise Ratio | | | | | |
| Current Channel A | | 74 | | dB | |
| Current Channel B | | 72 | | dB | |
| Voltage Channel | | 70 | | | |
| Signal-to-Noise-and-Distortion Ratio | | | | | |
| Current Channel A, Current Channel B | | 68 | | dB | |
| Voltage Channel | | 65 | | dB | |
| Bandwidth (–3 dB) | | 1.23 | | kHz | |
| CF1 AND CF2 PULSE OUTPUTS | | | | | |
| Maximum Output Frequency | | 206.9 | | kHz | |
| Duty Cycle | | 50 | | % | CF1 or CF2 frequency > 6.25 Hz |
| Active Low Pulse Width | | 80 | | ms | CF1 or CF2 frequency < 6.25 Hz |
| Jitter | | 0.04 | | % | CF1 or CF2 frequency = 1 Hz |
| Output High Voltage, V_{OH} | 2.4 | | | V | $I_{SOURCE} = 500 \mu A$ at 25°C |
| Output Low Voltage, V_{OL} | | | 0.4 | V | $I_{SINK} = 8 \text{ mA}$ at 25°C |
| REFERENCE | | | | | |
| REF Input Voltage Range | 1.19 | 1.2 | 1.21 | V | Nominal 1.2 V at REF pin T_{MIN} to T_{MAX} |
| Input Capacitance | | | 10 | pF | |
| Reference Error | | ±0.9 | | mV | $T_A = 25^\circ C$ |
| Output Impedance | 1.2 | | | k Ω | |
| Temperature Coefficient | | 10 | 50 | ppm/°C | |
| CLKIN/CLKOUT PINS | | | | | |
| Input Clock Frequency | | | 3.58 | MHz | All specifications CLKIN = 3.58 MHz |
| Crystal Equivalent Series Resistance | 30 | | 200 | Ω | |
| LOGIC INPUTS—\overline{RESET}, CLKIN, CS, SCLK, MOSI/SCL/Rx, MISO/SDA/Tx | | | | | |
| Input High Voltage, V_{INH} | 2.4 | | | V | $V_{DD} = 3.3 \text{ V} \pm 10\%$ |
| Input Low Voltage, V_{INL} | | | 0.8 | V | $V_{DD} = 3.3 \text{ V} \pm 10\%$ |
| Input Current, I_{IN} | | | | | $V_{IN} = 0 \text{ V}$ |
| MOSI/SCL/Rx, MISO/SDA/Tx, \overline{RESET} | | | –10 | μA | |
| CS, SCLK | | | 1 | μA | |
| Input Capacitance, C_{IN} | | | 10 | pF | |
| LOGIC OUTPUTS—IRQ, REVP, ZX, ZX_I, CLKOUT, MOSI/SCL/Rx, MISO/SDA/Tx | | | | | |
| Output High Voltage, V_{OH} | 3.0 | | | V | $V_{DD} = 3.3 \text{ V} \pm 10\%$ $I_{SOURCE} = 800 \mu A$ |
| Output Low Voltage, V_{OL} | | | 0.4 | V | $I_{SINK} = 2 \text{ mA}$ |
| POWER SUPPLY | | | | | |
| VDD | 3.0 | | | V | For specified performance 3.3 V – 10% |
| | | | 3.6 | V | 3.3 V + 10% |
| I_{DD} | | 7 | 9 | mA | |

TIMING CHARACTERISTICS

SPI Interface Timing

VDD = 3.3 V ± 10%, AGND = DGND = 0 V, on-chip reference, CLKIN = 3.58 MHz, T_{MIN} to T_{MAX} = -40°C to +85°C, unless otherwise noted.

Table 2.

| Parameter | Description | Min ¹ | Max ¹ | Unit |
|---------------------|---|------------------|------------------|------|
| t _{CS} | CS to SCLK edge | 50 | | ns |
| t _{SCLK} | SCLK period | 200 | | ns |
| t _{SL} | SCLK low pulse width | 80 | | ns |
| t _{SH} | SCLK high pulse width | 80 | | ns |
| t _{DAV} | Data output valid after SCLK edge | 80 | | ns |
| t _{DSU} | Data input setup time before SCLK edge | 70 | | ns |
| t _{DHD} | Data input hold time after SCLK edge | 5 | | ns |
| t _{DF} | Data output fall time | | 20 | ns |
| t _{DR} | Data output rise time | | 20 | ns |
| t _{SR} | SCLK rise time | | 20 | ns |
| t _{SF} | SCLK fall time | | 20 | ns |
| t _{DIS} | MISO disabled after CS rising edge | 5 | 40 | ns |
| t _{SFS} | CS high after SCLK edge | 0 | | ns |
| t _{SFS_LK} | CS high after SCLK edge (when writing to COMM_LOCK bit) | 1200 | | ns |

¹ Min and max values are typical minimum and maximum values.

SPI Interface Timing Diagram

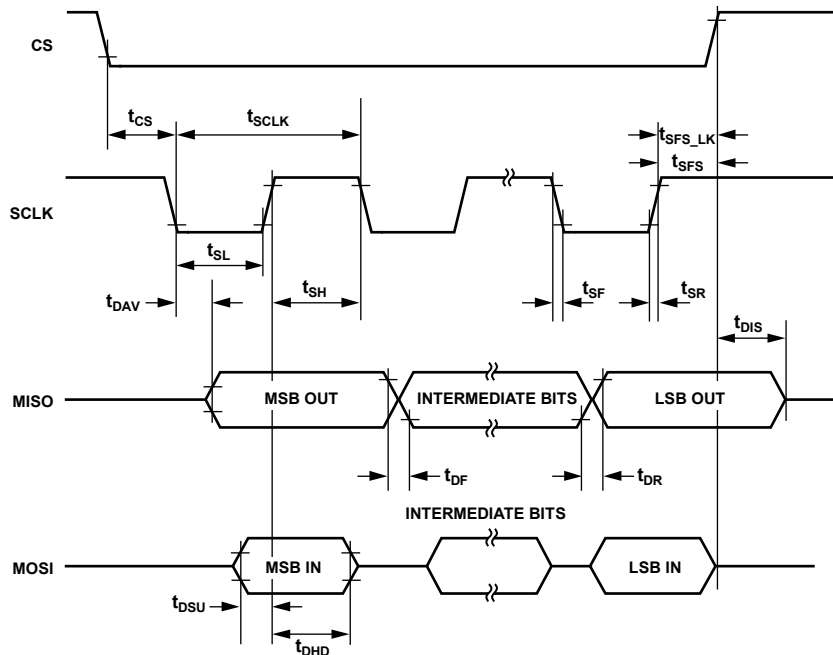

Figure 2. SPI Interface Timing

06320-003

I²C Interface Timing

VDD = 3.3 V ± 10%, AGND = DGND = 0 V, on-chip reference, CLKIN = 3.58 MHz, T_{MIN} to T_{MAX} = -40°C to +85°C, unless otherwise noted.

Table 3.

| Parameter | Description | Standard Mode | | Fast Mode | | Unit |
|---------------------|---|------------------|------------------|------------------|------------------|------|
| | | Min ¹ | Max ¹ | Min ¹ | Max ¹ | |
| f _{SCL} | SCL clock frequency | 0 | 100 | 0 | 400 | kHz |
| t _{HD;STA} | Hold time for a start or repeated start condition | 4.0 | | 0.6 | | μs |
| t _{LOW} | Low period of SCL clock | 4.7 | | 1.3 | | μs |
| t _{HIGH} | High period of SCL clock | 4.0 | | 0.6 | | μs |
| t _{SU;STA} | Setup time for a repeated start condition | 4.7 | | 0.6 | | μs |
| t _{HD;DAT} | Data hold time | 0 | 3.45 | 0 | 0.9 | μs |
| t _{SU;DAT} | Data setup time | 250 | | 100 | | ns |
| t _R | Rise time of SDA and SCL signals | | 1000 | 20 | 300 | ns |
| t _F | Fall time of SDA and SCL signals | | 300 | 20 | 300 | ns |
| t _{SU;STO} | Setup time for stop condition | 4.0 | | 0.6 | | μs |
| t _{BUF} | Bus-free time between a stop and start condition | 4.7 | | 1.3 | | μs |
| t _{SP} | Pulse width of suppressed spikes | N/A | | | 50 | ns |

¹ Min and max values are typical minimum and maximum values.

I²C Interface Timing Diagram

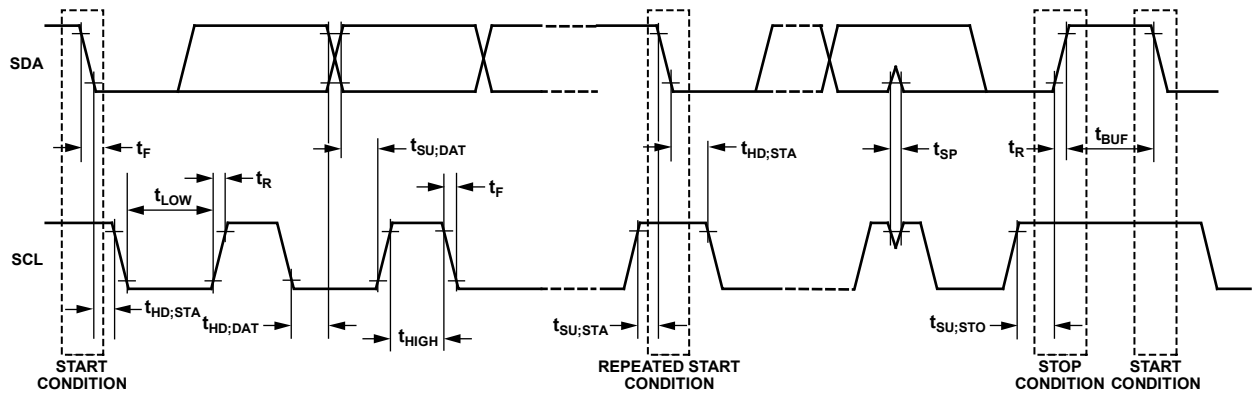

Figure 3. I²C Interface Timing

09320-002

ABSOLUTE MAXIMUM RATINGS

$T_A = 25^\circ\text{C}$, unless otherwise noted.

Table 4.

| Parameter | Rating |
|---|-----------------------|
| VDD to AGND | -0.3 V to +3.7 V |
| VDD to DGND | -0.3 V to +3.7 V |
| Analog Input Voltage to AGND, IAP, IAN, IBP, IBN, VP, VN | -2 V to +2 V |
| Reference Input Voltage to AGND | -0.3 V to VDD + 0.3 V |
| Digital Input Voltage to DGND | -0.3 V to VDD + 0.3 V |
| Digital Output Voltage to DGND | -0.3 V to VDD + 0.3 V |
| Operating Temperature | |
| Industrial Range | -40°C to +85°C |
| Storage Temperature Range | -65°C to +150°C |

Note that regarding the temperature profile used in soldering RoHS-compliant parts, Analog Devices, Inc., advises that reflow profiles should conform to J-STD 20 from JEDEC. Refer to the JEDEC website for the latest revision.

Stresses above those listed under Absolute Maximum Ratings may cause permanent damage to the device. This is a stress rating only; functional operation of the device at these or any other conditions above those indicated in the operational section of this specification is not implied. Exposure to absolute maximum rating conditions for extended periods may affect device reliability.

ESD CAUTION



ESD (electrostatic discharge) sensitive device. Charged devices and circuit boards can discharge without detection. Although this product features patented or proprietary protection circuitry, damage may occur on devices subjected to high energy ESD. Therefore, proper ESD precautions should be taken to avoid performance degradation or loss of functionality.

PIN CONFIGURATION AND FUNCTION DESCRIPTIONS

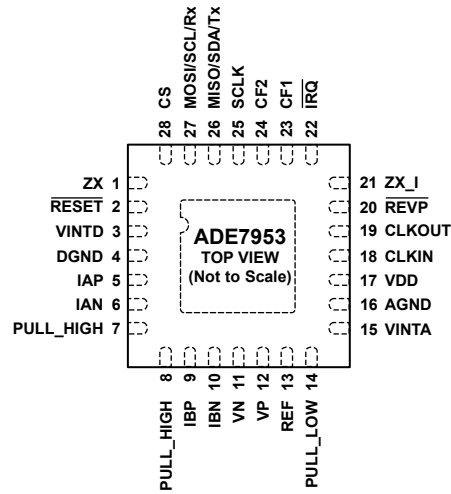

NOTES

1. CREATE A SIMILAR PAD ON THE PCB UNDER THE EXPOSED PAD. SOLDER THE EXPOSED PAD TO THE PAD ON THE PCB TO CONFER MECHANICAL STRENGTH TO THE PACKAGE. DO NOT CONNECT THE PADS TO AGND.

Figure 4. Pin Configuration

Table 5. Pin Function Descriptions

| Pin No. | Mnemonic | Description |
|---------|-----------|---|
| 1 | ZX | Voltage Channel Zero-Crossing Output Pin. See the Voltage Channel Zero Crossing section. This pin can be configured to output a range of alternative power quality signals (see the Alternative Output Functions section). |
| 2 | RESET | Active Low Reset Input. To initiate a hardware reset, this pin must be brought low for at minimum of 10 μ s. |
| 3 | VINTD | This pin provides access to the 2.5 V digital LDO. This pin should be decoupled with a 4.7 μ F capacitor in parallel with a 100 nF ceramic capacitor. |
| 4 | DGND | Ground Reference for the Digital Circuitry. |
| 5, 6 | IAP, IAN | Analog Input for Current Channel A (Phase Current Channel). This differential voltage input has a maximum input range of ± 500 mV. The maximum pin voltage for single-ended use is ± 250 mV. The PGA associated with this input has a maximum gain stage of 22 (see the Analog Inputs section). |
| 7, 8 | PULL_HIGH | These pins should be connected to VDD for proper operation. |
| 9, 10 | IBP, IBN | Analog Input for Current Channel B (Neutral Current Channel). This differential voltage input has a maximum input range of ± 500 mV. The PGA associated with this input has a maximum gain of 16 (see the Analog Inputs section). |
| 11, 12 | VN, VP | Analog Input for Voltage Channel. This differential voltage input has a maximum input range of ± 500 mV. The PGA associated with this input has a maximum gain of 16 (see the Analog Inputs section). |
| 13 | REF | This pin provides access to the on-chip voltage reference. The internal reference has a nominal voltage of 1.2 V. This pin should be decoupled with a 4.7 μ F capacitor in parallel with a 100 nF ceramic capacitor. Alternatively, an external reference voltage of 1.2 V can be applied to this pin (see the Reference Circuit section). |
| 14 | PULL_LOW | This pin should be connected to AGND for proper operation. |
| 15 | VINTA | This pin provides access to the 2.5 V analog LDO. This pin should be decoupled with a 4.7 μ F capacitor in parallel with a 100 nF ceramic capacitor. |
| 16 | AGND | Ground Reference for the Analog Circuitry. |
| 17 | VDD | Power Supply (3.3 V) for the ADE7953. For specified operation, the input to this pin should be within $3.3 \text{ V} \pm 10\%$. This pin should be decoupled with a 10 μ F capacitor in parallel with a 100 nF ceramic capacitor. |
| 18 | CLKIN | Master Clock Input for the ADE7953. An external clock can be provided at this input. Alternatively, a parallel resonant AT crystal can be connected across the CLKIN and CLKOUT pins to provide a clock source for the ADE7953. The clock frequency for specified operation is 3.58 MHz. Ceramic load capacitors of a few tens of picofarads should be used with the gate oscillator circuit. Refer to the crystal manufacturer's data sheet for the load capacitance requirements. |
| 19 | CLKOUT | A crystal can be connected across this pin and CLKIN to provide a clock source for the ADE7953. |

| Pin No. | Mnemonic | Description |
|---------|-------------------------|---|
| 20 | REVP | Reverse Power Output Indicator. See the Reverse Power section. This pin can be configured to output a range of alternative power quality signals (see the Alternative Output Functions section). |
| 21 | ZX_I | Current Channel Zero-Crossing Output Pin. See the Current Channel Zero Crossing section. This pin can be configured to output a range of alternative power quality signals (see the Alternative Output Functions section). |
| 22 | $\overline{\text{IRQ}}$ | Interrupt Output. See the ADE7953 Interrupts section. |
| 23 | CF1 | Calibration Frequency Output 1. |
| 24 | CF2 | Calibration Frequency Output 2. |
| 25 | SCLK | Serial Clock Input for the Serial Peripheral Interface. All serial communications are synchronized to the clock (see the SPI Interface section). If using the I ² C interface, this pin must be pulled high. If using the UART interface, this pin must be pulled to ground. |
| 26 | MISO/SDA/Tx | Data Output for SPI Interface/Bidirectional Data Line for I ² C Interface/Transmit Line for UART Interface. |
| 27 | MOSI/SCL/Rx | Data Input for SPI Interface/Serial Clock Input for I ² C Interface/Receive Line for UART Interface. |
| 28 | CS | Chip Select for SPI Interface. This pin must be pulled high if using the I ² C or UART interface. |
| | EPAD | Exposed Pad. Create a similar pad on the PCB under the exposed pad. Solder the exposed pad to the pad on the PCB to confer mechanical strength to the package. Do not connect the pads to AGND. |

TYPICAL PERFORMANCE CHARACTERISTICS

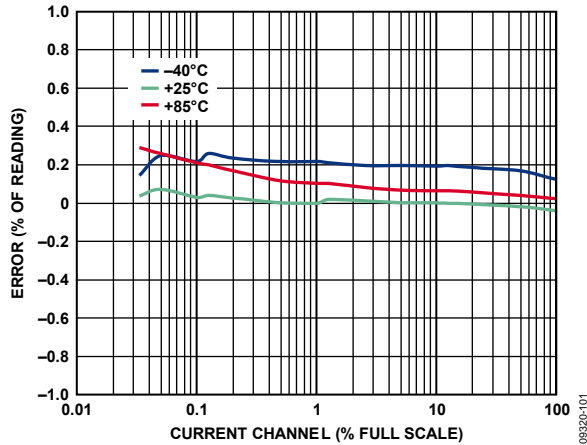

Figure 5. Current Channel A Active Energy Error as a Percentage of Reading (Gain = 1, Power Factor = 1) over Temperature with Internal Reference, Integrator Off

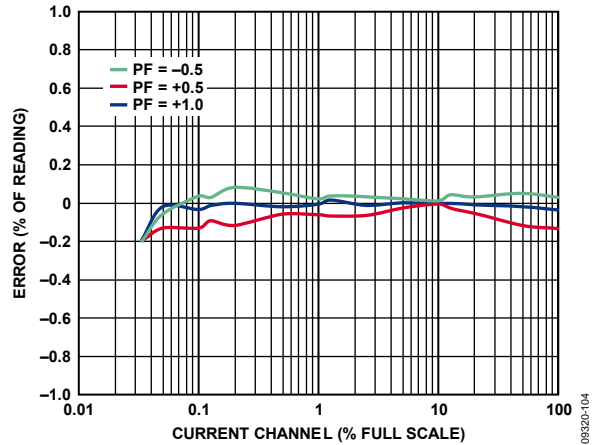

Figure 8. Current Channel A Active Energy Error as a Percentage of Reading (Gain = 22, Temperature = 25°C) over Power Factor with Internal Reference, Integrator Off

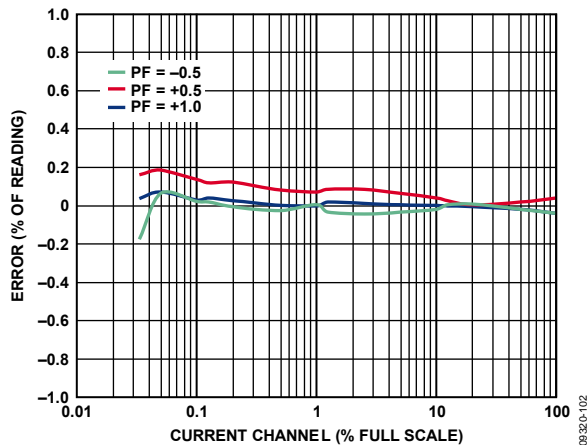

Figure 6. Current Channel A Active Energy Error as a Percentage of Reading (Gain = 1, Temperature = 25°C) over Power Factor with Internal Reference, Integrator Off

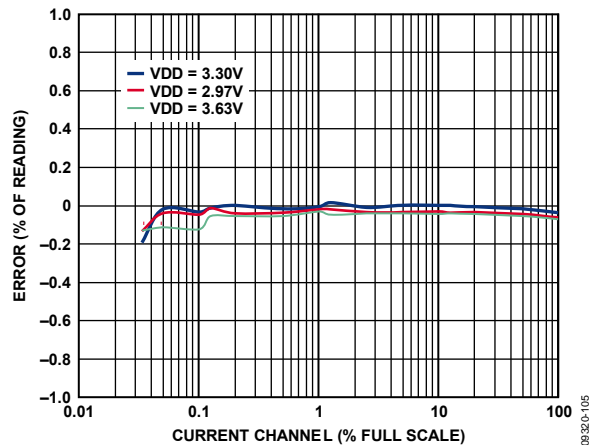

Figure 9. Current Channel A Active Energy Error as a Percentage of Reading (Gain = 22, Temperature = 25°C, Power Factor = 1) over Supply Voltage with Internal Reference, Integrator Off

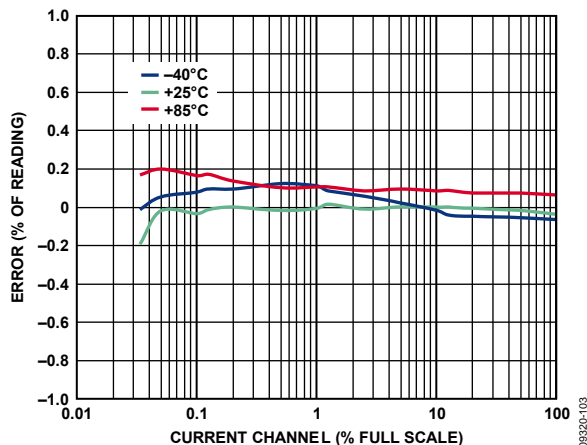

Figure 7. Current Channel A Active Energy Error as a Percentage of Reading (Gain = 22, Power Factor = 1) over Temperature with Internal Reference, Integrator Off

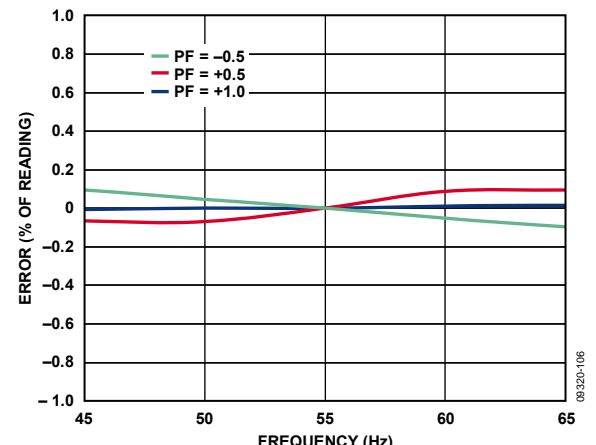

Figure 10. Current Channel A Active Energy Error as a Percentage of Reading (Gain = 22, Temperature = 25°C) over Frequency and Power Factor with Internal Reference, Integrator Off

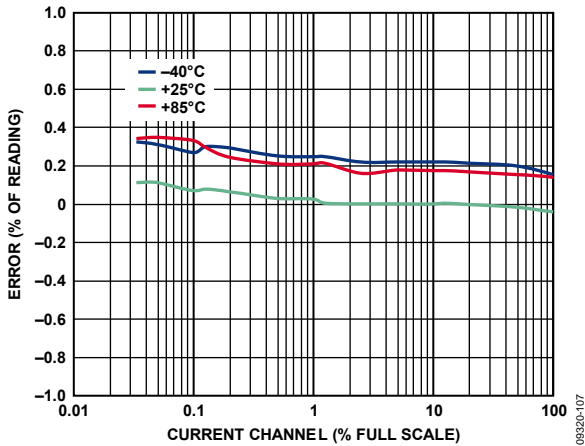

Figure 11. Current Channel A Reactive Energy Error as a Percentage of Reading (Gain = 1, Power Factor = 0) over Temperature with Internal Reference, Integrator Off

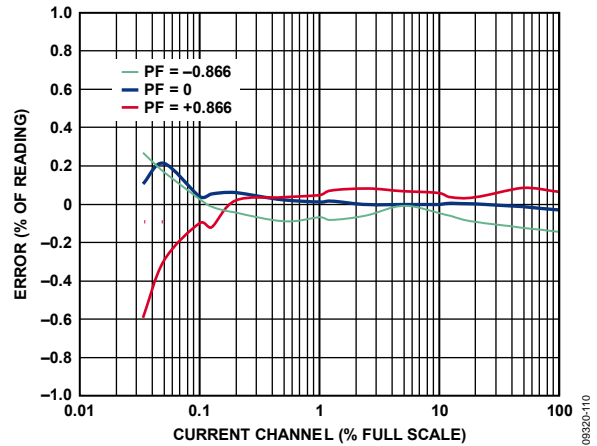

Figure 14. Current Channel A Reactive Energy Error as a Percentage of Reading (Gain = 22, Temperature = 25°C) over Power Factor with Internal Reference, Integrator Off

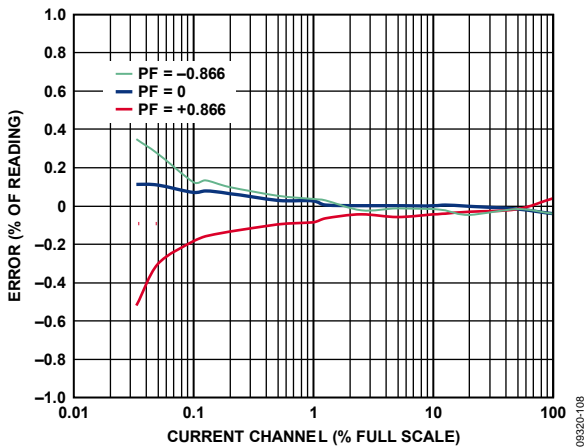

Figure 12. Current Channel A Reactive Energy Error as a Percentage of Reading (Gain = 1, Temperature = 25°C) over Power Factor with Internal Reference, Integrator Off

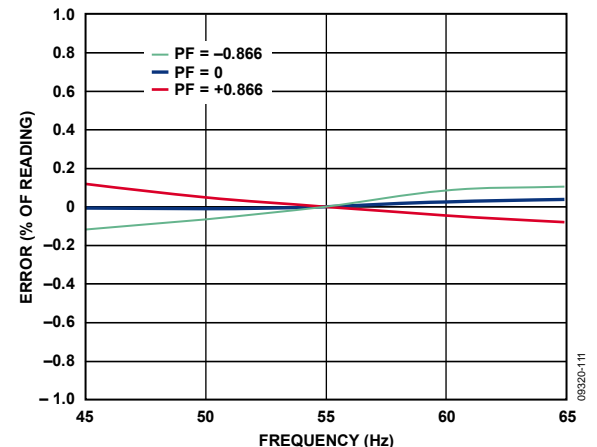

Figure 15. Current Channel A Reactive Energy Error as a Percentage of Reading (Gain = 22, Temperature = 25°C) over Frequency and Power Factor with Internal Reference, Integrator Off

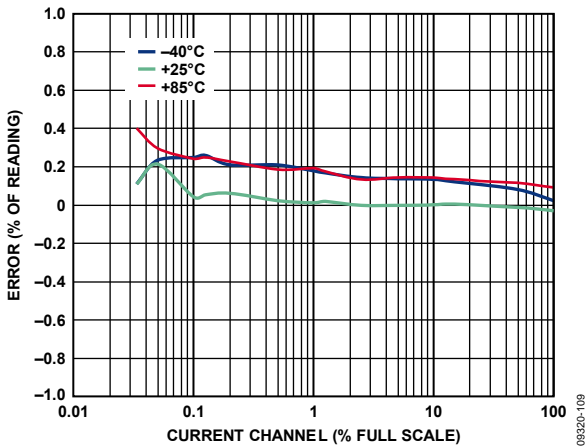

Figure 13. Current Channel A Reactive Energy Error as a Percentage of Reading (Gain = 22, Power Factor = 0) over Temperature with Internal Reference, Integrator Off

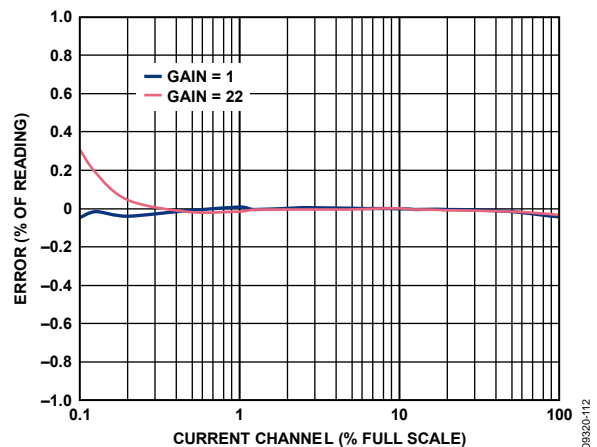

Figure 16. Current Channel A IRMS Error as a Percentage of Reading (Temperature = 25°C, Power Factor = 1) over Gain with Internal Reference, Integrator Off

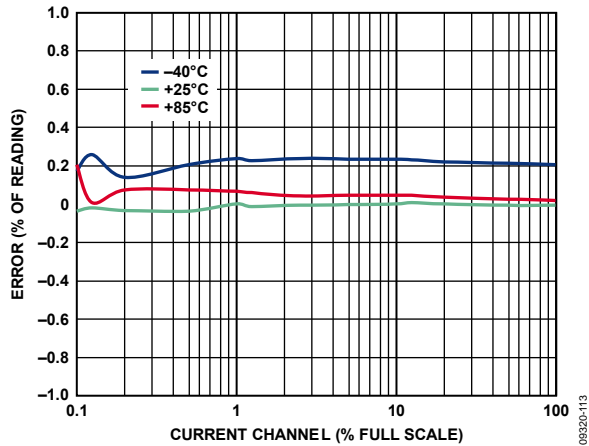

Figure 17. Current Channel B Active Energy Error as a Percentage of Reading (Gain = 1, Power Factor = 1) over Temperature with Internal Reference, Integrator Off

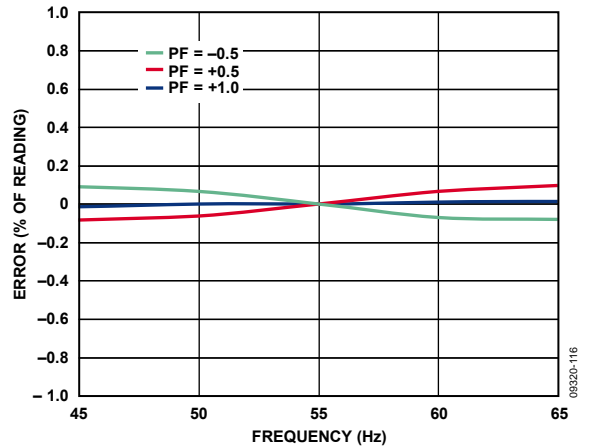

Figure 20. Current Channel B Active Energy Error as a Percentage of Reading (Gain = 1, Temperature = 25°C) over Frequency and Power Factor with Internal Reference, Integrator Off

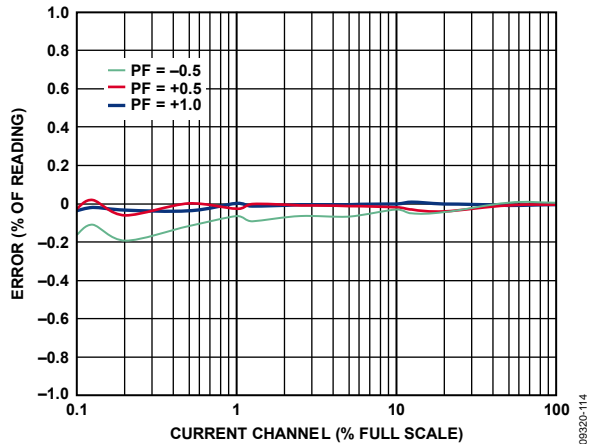

Figure 18. Current Channel B Active Energy Error as a Percentage of Reading (Gain = 1, Temperature = 25°C) over Power Factor with Internal Reference, Integrator Off

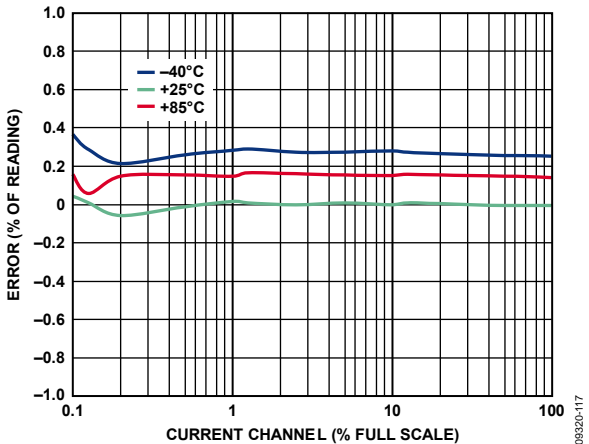

Figure 21. Current Channel B Reactive Energy Error as a Percentage of Reading (Gain = 1, Power Factor = 0) over Temperature with Internal Reference, Integrator Off

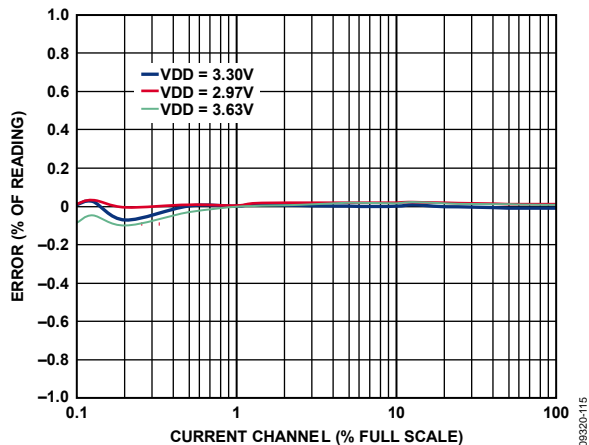

Figure 19. Current Channel B Active Energy Error as a Percentage of Reading (Gain = 1, Temperature = 25°C, Power Factor = 1) over Supply Voltage with Internal Reference, Integrator Off

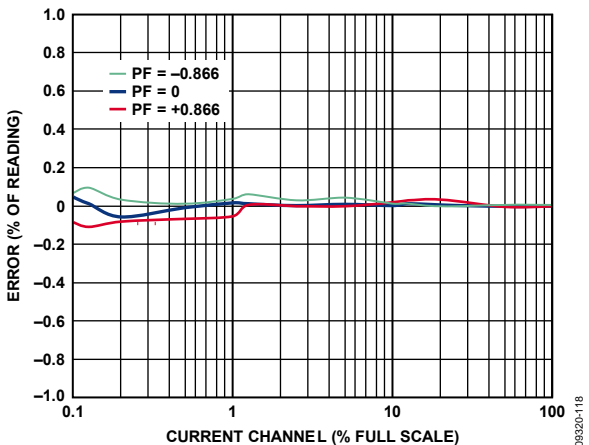

Figure 22. Current Channel B Reactive Energy Error as a Percentage of Reading (Gain = 1, Temperature = 25°C) over Power Factor with Internal Reference, Integrator Off

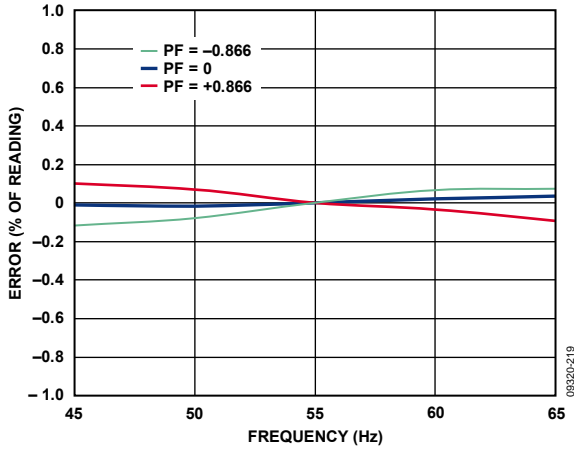

Figure 23. Current Channel B Reactive Energy Error as a Percentage of Reading (Gain = 1, Temperature = 25°C) over Frequency and Power Factor with Internal Reference, Integrator Off

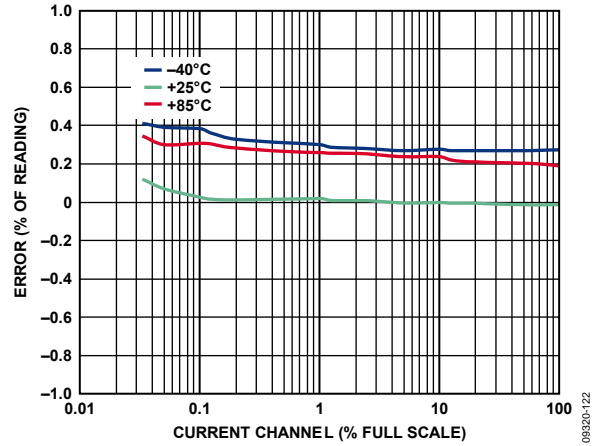

Figure 26. Current Channel A Active Energy Error as a Percentage of Reading (Gain = 16, Power Factor = 1) over Temperature with Internal Reference, Integrator On

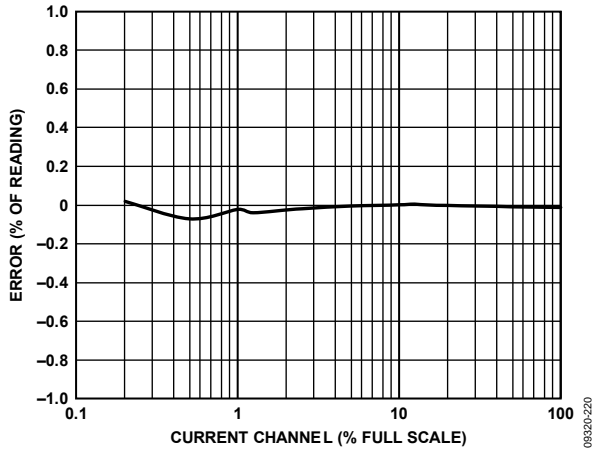

Figure 24. Current Channel B IRMS Error as a Percentage of Reading (Gain = 1, Temperature = 25°C, Power Factor = 1) with Internal Reference, Integrator Off

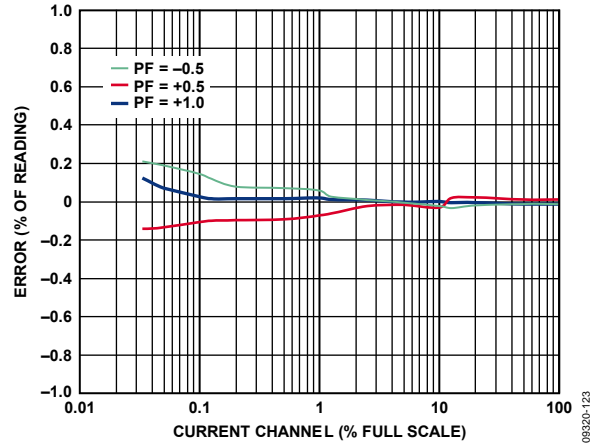

Figure 27. Current Channel A Active Energy Error as a Percentage of Reading (Gain = 16, Temperature = 25°C) over Power Factor with Internal Reference, Integrator On

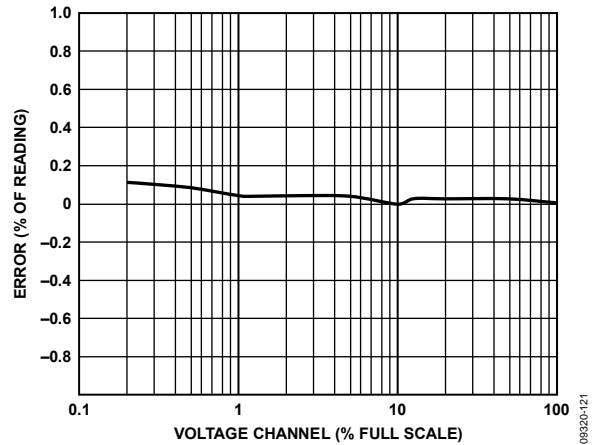

Figure 25. VRMS Error as a Percentage of Reading (Temperature = 25°C, Power Factor = 1) with Internal Reference, Integrator Off

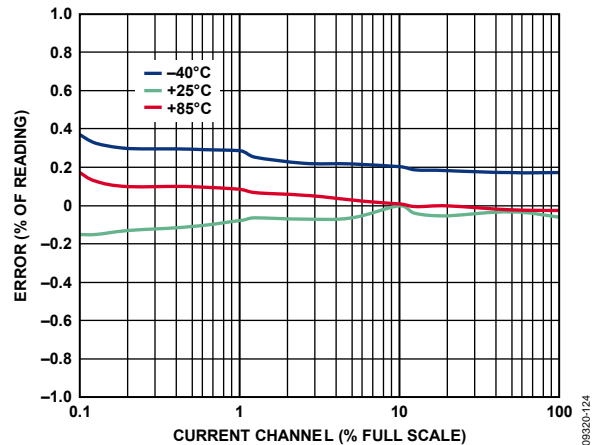

Figure 28. Current Channel B Active Energy Error as a Percentage of Reading (Gain = 16, Power Factor = 1) over Temperature with Internal Reference, Integrator On

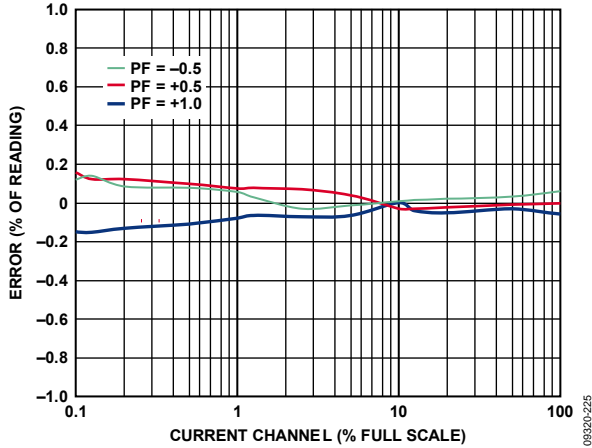

Figure 29. Current Channel B Active Energy Error as a Percentage of Reading (Gain = 16, Temperature = 25°C) over Power Factor with Internal Reference, Integrator On

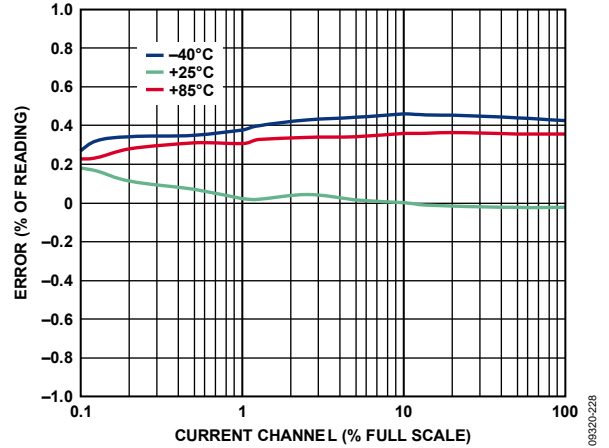

Figure 32. Current Channel B Reactive Energy Error as a Percentage of Reading (Gain = 16, Power Factor = 0) over Temperature with Internal Reference, Integrator On

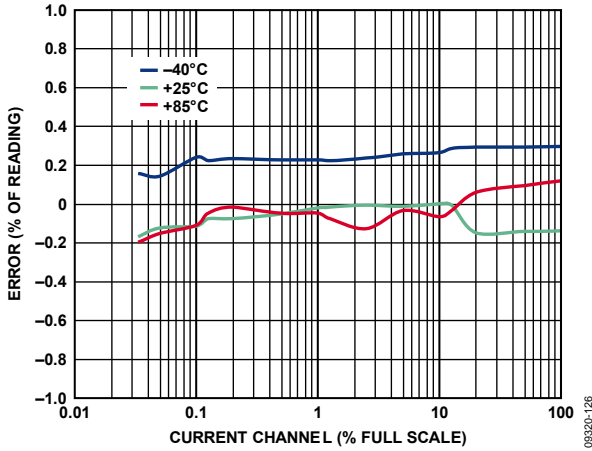

Figure 30. Current Channel A Reactive Energy Error as a Percentage of Reading (Gain = 16, Power Factor = 0) over Temperature with Internal Reference, Integrator On

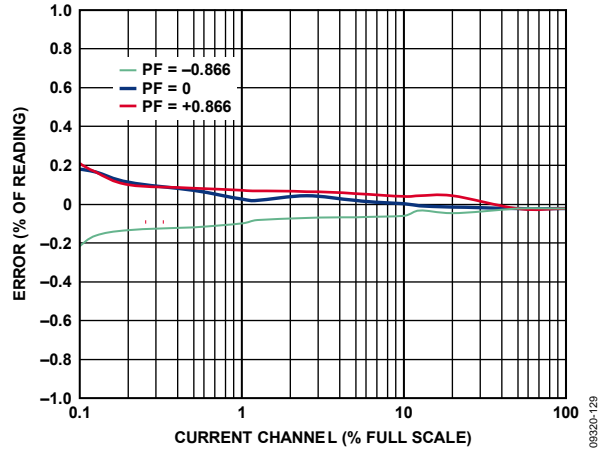

Figure 33. Current Channel B Reactive Energy Error as a Percentage of Reading (Gain = 16, Temperature = 25°C) over Power Factor with Internal Reference, Integrator On

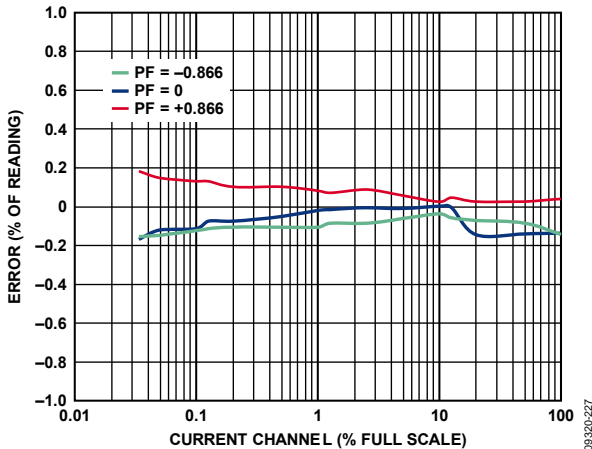

Figure 31. Current Channel A Reactive Energy Error as a Percentage of Reading (Gain = 16, Temperature = 25°C) over Power Factor with Internal Reference, Integrator On

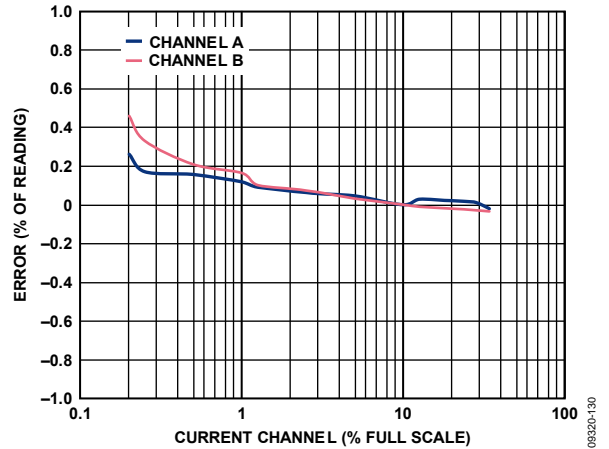

Figure 34. IRMS Error as a Percentage of Reading (Gain = 16, Temperature = 25°C) with Internal Reference, Integrator On

TEST CIRCUIT

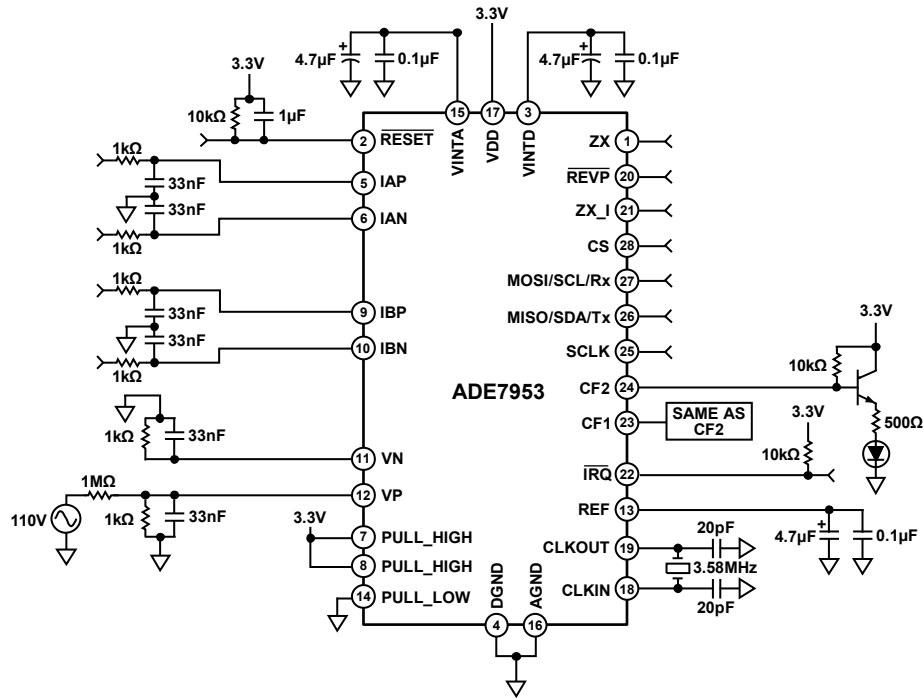

Figure 35. Test Circuit

09320-099

TERMINOLOGY

Measurement Error

The error associated with the energy measurement made by the ADE7953 is defined by

$$\text{Measurement Error} = \frac{\text{Energy Registered by ADE7953} - \text{True Energy}}{\text{True Energy}} \times 100\% \quad (1)$$

Phase Error Between Channels

The high-pass filter (HPF) and digital integrator introduce a slight phase mismatch between the current channels and the voltage channel. The all-digital design ensures that the phase matching between the current channels and the voltage channel is within $\pm 0.05^\circ$ over a range of 45 Hz to 65 Hz. This internal phase mismatch can be combined with the external phase error (from current sensor or component tolerance) and calibrated with the phase calibration registers.

Power Supply Rejection (PSR)

PSR quantifies the ADE7953 measurement error as a percentage of reading when the power supplies are varied. For the ac PSR measurement, a reading at nominal supplies (3.3 V) is taken. A second reading is obtained with the same input signal levels when an ac signal (120 mV rms/100 Hz) is introduced onto the supplies. Any error introduced by this ac signal is expressed as a percentage of reading (see the Measurement Error definition). For the dc PSR measurement, a reading at nominal supplies (3.3 V) is taken. A second reading is obtained with the same input signal levels when the power supplies are varied by $\pm 10\%$. Any error introduced is again expressed as a percentage of reading.

ADC Offset Error

The ADC offset error refers to the dc offset associated with the analog inputs to the ADCs. It means that, with the analog inputs connected to AGND, the ADCs still see a dc analog input signal. The magnitude of the offset depends on the gain and input range selection. However, the offset is removed from the current and voltage channels by a high-pass filter (HPF), and the power calculation is not affected by this offset.

Gain Error

The gain error in the ADCs of the ADE7953 is defined as the per-channel difference between the measured ADC output code (minus the offset) and the ideal output code (see the Current Channel ADCS section and the Voltage Channel ADC section). The difference is expressed as a percentage of the ideal code.

ADE7953 POWER-UP PROCEDURE

The ADE7953 contains an on-chip power supply monitor that supervises the power supply (VDD). While the voltage applied to the VDD pin is below $2\text{ V} \pm 10\%$, the chip is in an inactive state. Once VDD crosses the $2\text{ V} \pm 10\%$ threshold, the power supply monitor keeps the ADE7953 in an inactive state for an additional 26 ms. This time delay allows VDD to reach the minimum specified operating voltage of $3.3\text{ V} - 10\%$. Once the minimum specified operating voltage is met, the internal circuitry is enabled; this is accomplished in approximately 40 ms.

Once the start-up sequence is complete and the ADE7953 is ready to receive communication from a microcontroller, the reset flag is set in the IRQSTATA register (Address 0x22D and Address 0x32D). An external interrupt is triggered on the IRQ pin. The reset interrupt is enabled by default and cannot be disabled, hence an external interrupt always occurs at the end of a power-up procedure, hardware or software reset.

It is highly recommended that the reset interrupt is used by the microcontroller to gate the first communication with the ADE7953. If the interrupt is not used, a timeout can be implemented; however, as the start-up sequence can vary part-to-part and over temperature, a timeout of at least 100 ms is recommended. The reset interrupt provides the most efficient way of monitoring the completion of the ADE7953 start-up sequence.

Once the start-up sequence is complete, communication with the ADE7953 can begin. See the Communicating with the ADE7953 section for further details.

REQUIRED REGISTER SETTING

For optimum performance, Register Address 0x120 must be configured by the user after powering up the ADE7953. This register ensures that the optimum timing configuration is selected to maximize the accuracy and dynamic range. This register is not set by default and thus must be written by the user each time the ADE7953 is powered up. Register 0x120 is a protected register and thus a key must be written to allow the register to be modified. The following sequence should be followed:

- Write 0xAD to Register Address 0xFE: This unlocks the register 0x120
- Write 0x30 to Register Address 0x120: This configures the optimum settings

The above two instructions must be performed in succession to be successful.

THEORY OF OPERATION

ANALOG INPUTS

The ADE7953 includes three analog inputs that form two current channels and one voltage channel. In a standard configuration, Current Channel A is used to measure the phase current, and Current Channel B is used to measure the neutral current. The voltage channel input measures the difference between the phase voltage and the neutral voltage. The ADE7953 can, however, be used with alternative voltage and current combinations as long as the analog input specifications described in this section are met.

Current Channel A

Current Channel A is a fully differential voltage input that is designed to be used with a current sensor. This input is driven by two pins: IAP (Pin 5) and IAN (Pin 6). The maximum differential voltage that can be applied to IAP and IAN is ± 500 mV. A common-mode voltage of less than ± 25 mV is recommended. Common-mode voltages in excess of this recommended value may limit the available dynamic range. A programmable gain amplifier (PGA) stage is provided on Current Channel A with gain options of 1, 2, 4, 8, 16, and 22 (see Table 6).

The maximum full-scale input of Current Channel A is ± 250 mV when using a single-ended configuration and, therefore, when using a gain setting of 1, the dynamic range is limited. The Current Channel A gain is configured by writing to the PGA_IA register (Address 0x008). By default, the Current Channel A PGA is set to 1. A gain option of 22 is offered exclusively on Current Channel A, allowing high accuracy measurement for signals of very small amplitude. This configuration is particularly useful when using small value shunt resistors or Rogowski coils.

Current Channel B

Current Channel B is a fully differential voltage input that is designed to be used with a current sensor. This input is driven by two pins: IBP (Pin 9) and IBN (Pin 10). The maximum differential voltage that can be applied to IBP and IBN is ± 500 mV. A common-mode voltage of less than ± 25 mV is recommended. Common-mode voltages in excess of this recommended value may limit the available dynamic range. A PGA gain stage is provided on Current Channel B with gain options of 1, 2, 4, 8, and 16 (see Table 6). The Current Channel B gain is configured by writing to the PGA_IB register (Address 0x009). By default, the Current Channel B PGA is set to 1.

Voltage Channel

The voltage channel input a full differential input driven by two pins: VP (Pin 12) and VN (Pin 11). The voltage channel is typically connected in a single-ended configuration. The maximum single-ended voltage that can be applied to VP is ± 500 mV with respect to VN. A common-mode voltage of less than ± 25 mV is recommended. Common-mode voltages in excess of this recommended value may limit the dynamic range capabilities of the ADE7953. A PGA gain stage is provided on

the voltage channel with gain options of 1, 2, 4, 8, and 16 (see Table 6).

The voltage channel gain is configured by writing to the PGA_V register (Address 0x007). By default, the voltage channel PGA is set to 1.

Table 6. PGA Gain Settings

| Gain | Full-Scale Differential Input (mV) | PGA_IA[2:0] (Addr 0x008) | PGA_IB[2:0] (Addr 0x009) | PGA_V[2:0] (Addr 0x007) |
|------|------------------------------------|--------------------------|--------------------------|-------------------------|
| 1 | ± 500 | 000 ¹ | 000 | 000 |
| 2 | ± 250 | 001 | 001 | 001 |
| 4 | ± 125 | 010 | 010 | 010 |
| 8 | ± 62.5 | 011 | 011 | 011 |
| 16 | ± 31.25 | 100 | 100 | 100 |
| 22 | ± 22.7 | 101 | N/A | N/A |

¹ When a gain of 1 is selected on Current Channel A, the maximum pin input is limited to ± 250 mV. Therefore, when using a single-ended configuration, the maximum input is ± 250 mV with respect to AGND.

ANALOG-TO-DIGITAL CONVERSION

The analog-to-digital conversion in the ADE7953 is performed by three second-order Σ - Δ modulators. For the sake of clarity, the block diagram in Figure 36 shows the operation of a first-order Σ - Δ modulator. The analog-to-digital conversion consists of a Σ - Δ modulator followed by a low-pass filter stage.

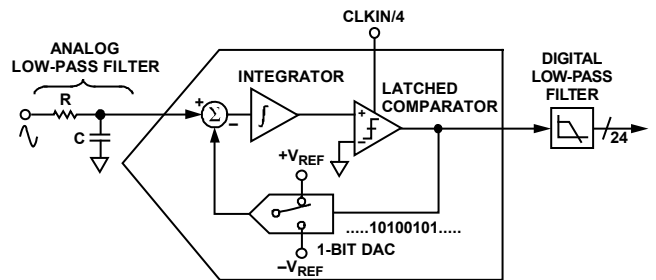

Figure 36. Σ - Δ Conversion

The Σ - Δ modulator converts the input signal into a continuous serial stream of 1s and 0s at a rate determined by the sampling clock. The ADE7953 sampling clock is equal to 895 kHz (CLKIN/4). The 1-bit DAC in the feedback loop is driven by the serial data stream. The DAC output is subtracted from the input signal. If the loop gain is high enough, the average value of the DAC output (and, therefore, the bit stream) can approach that of the input signal level. For any given input value in a single sampling interval, the data from the 1-bit ADC is virtually meaningless. A meaningful result is obtained only when a large number of samples is averaged. This averaging is carried out in the second part of the ADC, the digital low-pass filter. By averaging a large number of bits from the modulator, the low-pass filter can produce 24-bit data-words that are proportional to the input signal level. The Σ - Δ converter uses two techniques—oversampling and noise shaping—to achieve high resolution from what is essentially a 1-bit conversion technique.

Oversampling

Oversampling is the first technique used to achieve high resolution. Oversampling means that the signal is sampled at a rate (frequency) that is many times higher than the bandwidth of interest. For example, the sampling rate in the ADE7953 is 895 kHz, and the bandwidth of interest is 40 Hz to 1.23 kHz. Oversampling has the effect of spreading the quantization noise (noise due to sampling) over a wider bandwidth. With the noise spread more thinly over a wider bandwidth, the quantization noise in the band of interest is lowered (see Figure 37).

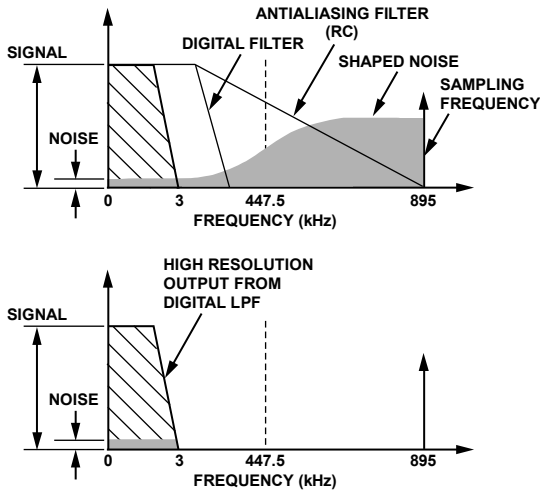

Figure 37. Noise Reduction due to Oversampling and Noise Shaping in the Analog Modulator

However, oversampling alone is not sufficient to improve the signal-to-noise ratio (SNR) in the bandwidth of interest. For example, an oversampling ratio of 4 is required to increase the SNR by only 6 dB (1 bit). To keep the oversampling ratio at a reasonable level, it is possible to shape the quantization noise so that the majority of the noise lies at the higher frequencies (see the following section).

Noise Shaping

Noise shaping is the second technique used to achieve high resolution. In the Σ - Δ modulator, the noise is shaped by the integrator, which has a high-pass-type response for the quantization noise due to feedback. The result is that most of the noise is at the higher frequencies, where it can be removed by the digital low-pass filter. This noise shaping is shown in Figure 37.

Antialiasing Filter

As shown in Figure 36, an external low-pass RC filter is required on the input to each modulator. The role of this filter is to prevent aliasing. Aliasing refers to the frequency components in the input signal that are folded back and appear in the sampled signal. This effect occurs with signals that are higher than half the sampling rate of the ADC (also known as the Nyquist frequency) appearing in the sampled signal at a frequency below half the sampling rate. This concept is depicted in Figure 38.

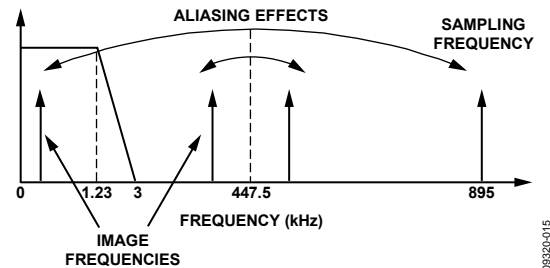

Figure 38. Aliasing Effect

The arrows shown in Figure 38 depict the frequency components above the Nyquist frequency (447.5 kHz in the case of the ADE7953) being folded back down. Aliasing occurs with all ADCs, regardless of the architecture.

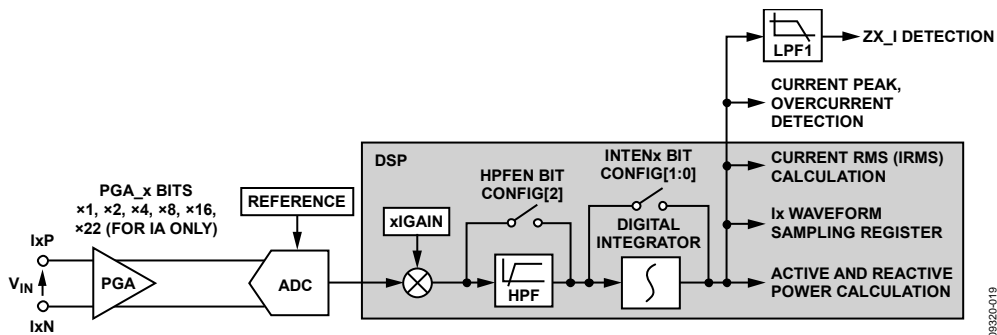

Figure 39. Current Channel ADC and Signal Path

CURRENT CHANNEL ADCs

Figure 39 shows the ADC signal path and signal processing for Current Channel A, which is accessed through the IAP and IAN pins. The signal path for Current Channel B is identical and is accessed through the IBP and IBN pins. The ADC output is a two's complement, 24-bit data-word that is available at a rate of 6.99 kSPS (thousand samples per second). With the specified full-scale analog input of ± 250 mV and a PGA_Ix gain setting of 2, the ADC produces its maximum output code. The ADC output swings between $-6,500,000$ LSBs (decimal) and $+6,500,000$ LSBs. This output varies from part to part.

As shown in Figure 39, there is a high-pass filter (HPF) in each current channel signal path. The HPF is enabled by default and removes any dc offset in the ADC output. It is highly recommended that this filter be enabled at all times, but it can be disabled by clearing the HPFEN bit (Bit 2) in the CONFIG register (Address 0x102). Clearing the HPFEN bit disables the filters in both current channels and in the voltage channel.

di/dt Current Sensor and Digital Integrator

As shown in Figure 39, the current channel signal path for both Channel A and Channel B includes an internal digital integrator. This integrator is disabled by default and is required only when interfacing with a di/dt sensor, such as a Rogowski coil. When using either a shunt resistor or a current transformer (CT), this integrator is not required and should remain disabled.

A di/dt sensor detects changes in the magnetic field caused by ac current. Figure 40 shows the principle of a di/dt current sensor.

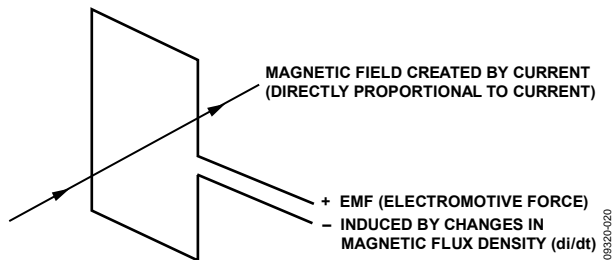

Figure 40. Principle of a di/dt Current Sensor

The flux density of a magnetic field induced by a current is directly proportional to the magnitude of the current. Changes in the magnetic flux density passing through a conductor loop generate an electromotive force (EMF) between the two ends of the loop. The EMF is a voltage signal that is proportional to the differential of the current over time (di/dt). The voltage output from the di/dt sensor is determined by the mutual inductance between the current-carrying conductor and the di/dt sensor. The current signal must be recovered from the di/dt signal before it can be used. An integrator is therefore necessary to restore the signal to its original form.

The ADE7953 has a built-in digital integrator on each current channel that recovers the current signal from the di/dt sensor. Both digital integrators are disabled by default. The digital integrator on Current Channel A is enabled by setting the INTENA bit (Bit 0) in the CONFIG register (Address 0x102). The digital integrator on Current Channel B is enabled by setting the INTENB bit (Bit 1) in the CONFIG register (Address 0x102).

VOLTAGE CHANNEL ADC

Figure 41 shows the ADC signal path and signal processing for the voltage channel input, which is accessed through the VP and VN pins. The ADC output is a two's complement, 24-bit data-word that is available at a rate of 6.99 kSPS (thousand samples per second). With the specified full-scale analog input of ± 500 mV and a PGA_V gain setting of 1, the ADC produces its maximum output code. The ADC output swings between $-6,500,000$ LSBs (decimal) and $+6,500,000$ LSBs. Note that this output varies from part to part.

As shown in Figure 41, there is a high-pass filter (HPF) in the voltage channel signal path. The HPF is enabled by default and removes any dc offset in the ADC output. It is highly recommended that this filter be enabled at all times, but it can be disabled by clearing the HPFEN bit (Bit 2) in the CONFIG register (Address 0x102). Clearing the HPFEN bit disables the filters in both current channels and in the voltage channel.

REFERENCE CIRCUIT

The ADE7953 has an internal voltage reference of 1.2 V nominal, which appears on the REF pin. This reference voltage is used by the ADCs in the ADE7953. The REF pin can be overdriven by an external source, for example an external 1.2 V reference. The voltage of the ADE7953 internal reference drifts slightly over temperature (see the Specifications section). The value of the temperature drift may vary slightly from part to part. A drift of x% in

the reference results in a 2x% deviation in meter accuracy. The reference drift is typically minimal and is usually much smaller than the drift of other components in the meter. By default, the ADE7953 is configured to use the internal reference. If Bit 0 of the EX_REF register (Address 0x800) is set to 1, an external voltage reference can be applied to the REF pin.

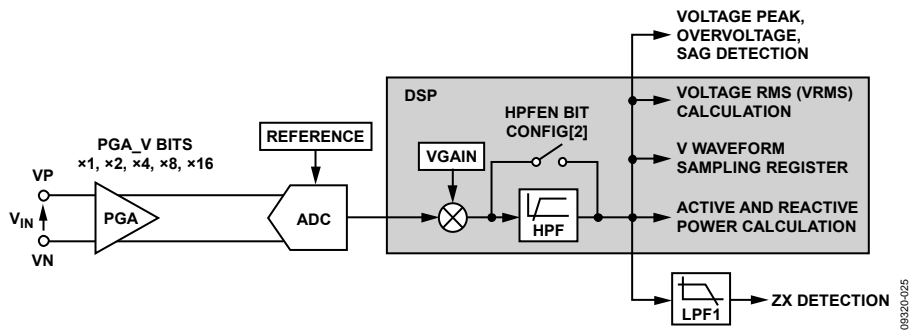

Figure 41. Voltage Channel ADC and Signal Path

ROOT MEAN SQUARE MEASUREMENT

Root mean square (rms) is a measurement of the magnitude of an ac signal. Specifically, the rms of an ac signal is equal to the amount of dc required to produce an equivalent amount of power in the load. The rms is expressed mathematically in Equation 1.

$$RMS = \sqrt{\frac{1}{t} \int_0^t f^2(t) dt} \tag{1}$$

For time-sampled signals, rms calculation involves squaring the signal, taking the average, and obtaining the square root.

$$RMS = \sqrt{\frac{1}{N} \sum_{n=1}^N f^2[n]} \tag{2}$$

As implied by Equation 2, the rms measurement contains information from the fundamental and all harmonics over a 1.23 kHz measurement bandwidth.

The ADE7953 provide rms measurements for Current Channel A, Current Channel B, and the voltage channel simultaneously. These measurements have a settling time of approximately 200 ms and are updated at a rate of 6.99 kHz.

CURRENT CHANNEL RMS CALCULATION

The ADE7953 provides rms measurements for both Current Channel A and Current Channel B. Figure 42 shows the signal path for this calculation. The signal processing is identical for Current Channel A and Current Channel B.

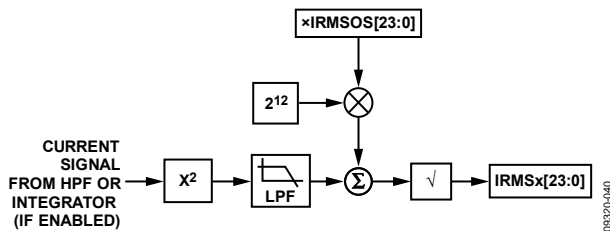

Figure 42. Current Channel RMS Signal Processing

As shown in Figure 42, the current channel ADC output samples are used to continually compute the rms. The rms is achieved by low-pass filtering the square of the output signal and then taking a square root of the result. The 24-bit unsigned rms measurements for Current Channel A and Current Channel B are available in

the IRMSA (Address 0x21A and Address 0x31A) and IRMSB (Address 0x21B and Address 0x31B) registers, respectively. Both of these registers are updated at a rate of 6.99 kHz. With full-scale inputs on Current Channel A and Current Channel B, the expected reading on the IRMSA and IRMSB register is 9032007d.

Because the LPF used in the rms signal path is not ideal, it is recommended that the IRMSx registers be read synchronously to the zero-crossing signal (see the Zero-Crossing Detection section). This helps to stabilize reading-to-reading variation by removing the effect of any 2ω ripple present on the rms measurement.

VOLTAGE CHANNEL RMS CALCULATION

The ADE7953 provides an rms measurement on the voltage channel. Figure 43 shows the signal path for this calculation.

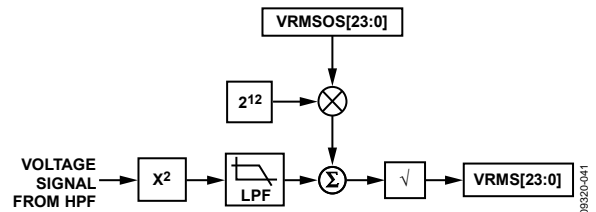

Figure 43. Voltage Channel RMS Signal Processing

As shown in Figure 43, the voltage channel ADC output samples are used to continually compute the rms. The rms is achieved by low-pass filtering the square of the output signal and then taking a square root of the result. The 24-bit unsigned voltage channel rms measurement is available in the VRMS register (Address 0x21C and Address 0x31C). This register is updated at a rate of 6.99 kHz. With full-scale inputs on the voltage channel, a VRMS reading of 9032007d can be expected.

Because the LPF used in the rms signal path is not ideal, it is recommended that the VRMS register be read synchronously to the zero-crossing signal (see the Zero-Crossing Detection section). This helps to stabilize reading-to-reading variation by removing the effect of any 2ω ripple present on the rms measurement.

ACTIVE POWER CALCULATION

Power is defined as the rate of energy flow from the source to the load. It is defined as the product of the voltage and current waveforms. The resulting waveform is called the instantaneous power signal and is equal to the rate of energy flow at every instant of time. The unit of power is the watt or joules/sec.

$$V(t) = \sqrt{2} \times V \times \sin(\omega t) \tag{3}$$

$$I(t) = \sqrt{2} \times I \times \sin(\omega t) \tag{4}$$

where:

V is the rms voltage.

I is the rms current.

$$P(t) = V(t) \times I(t) \tag{5}$$

$$P(t) = VI - VI \times \cos(2\omega t) \tag{6}$$

The average power over an integral number of line cycles (n) is given by the expression in Equation 7.

$$P = \frac{1}{nT} \int_0^{nT} P(t) dt = VI \tag{7}$$

where:

P is the active or real power.

T is the line cycle period.

The active power is equal to the dc component of the instantaneous power signal ($P(t)$ in Equation 5). The active power is therefore equal to VI . This relationship is used to calculate active power in the ADE7953. Figure 44 illustrates this concept.

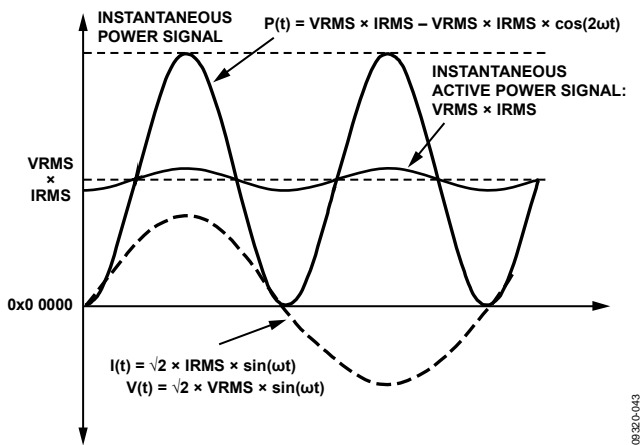

Figure 44. Active Power Calculation

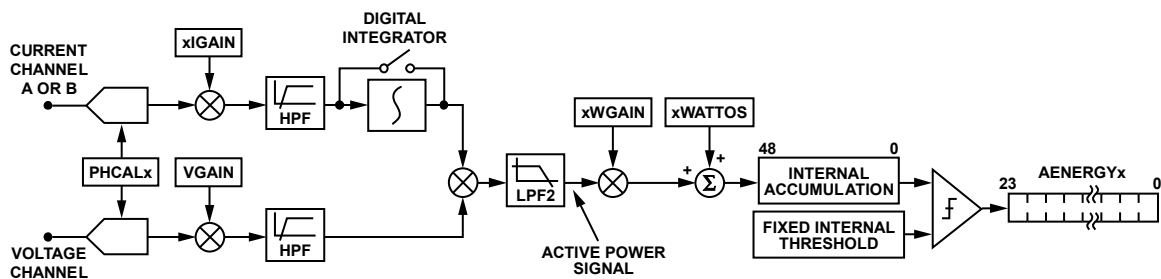

Figure 45. Active Energy Signal Chain

The signal chain for the active power and energy calculations in the ADE7953 is shown in Figure 45. The instantaneous power signal $P(t)$ is generated by multiplying the current and voltage signals. The dc component of the instantaneous power signal is then extracted by LPF2 (low-pass filter) to obtain the active power information. Because LPF2 does not have an ideal “brick wall” frequency response, the active power signal has some ripple associated with it. This ripple is sinusoidal and has a frequency equal to twice the line frequency. Because the ripple is sinusoidal in nature, it is removed when the active power signal is integrated to compute the active energy (see the Active Energy Calculation section).

The ADE7953 computes the active power simultaneously on Current Channel A and Current Channel B and stores the resulting measurements in the AWATT (Address 0x212 and Address 0x312) and BWATT (Address 0x213 and Address 0x313) registers, respectively. With full-scale inputs, the expected reading in the AWATT and BWATT registers is approximately 4862401 LSBs (decimal).

The active power measurements are taken over a bandwidth of 1.23 kHz and include the effects of any harmonics within that range. The active power registers are updated at a rate of 6.99 kHz and can be read using the waveform sampling mode (see the Instantaneous Powers and Waveform Sampling section).

SIGN OF ACTIVE POWER CALCULATION

The active power measurement in the ADE7953 is a signed calculation. If the phase differential between the current and voltage waveforms is more than 90° , the power is negative. Negative power indicates that energy is being injected back into the grid. The ACCMODE register (Address 0x201 and Address 0x301) includes two sign indication bits that show the sign of the active power of Current Channel A (APSIGN_A) and Current Channel B (APSIGN_B). See the Sign Indication section for more information.

ACTIVE ENERGY CALCULATION

As described in the Active Power Calculation section, power is defined as the rate of energy flow. This relationship can be expressed mathematically as shown in Equation 8.

$$P = \frac{dE}{dt} \tag{8}$$

where:

P is power.

E is energy.

Conversely, energy is given as the integral of power.

$$E = \int Pdt \tag{9}$$

The ADE7953 achieves the integration of the active power signal in two stages. In the first stage, the active power signals are accumulated in an internal 48-bit register every 143 μs (6.99 kHz) until an internal fixed threshold is reached. When this threshold is reached, a pulse is generated and is accumulated in 24-bit, user-accessible accumulation registers. The internal threshold results in a maximum accumulation rate of approximately 206.9 kHz with full-scale inputs. This process occurs simultaneously on Current Channel A and Current Channel B, and the resulting readings can be read in the 24-bit AENERGYA (Address 0x21E and Address 0x31E) and AENERGYB (Address 0x21F and Address 0x31F) registers. Both stages of the accumulation are signed and, therefore, negative energy is subtracted from positive energy.

This discrete time accumulation, or summation, is equivalent to integration in continuous time. Equation 10 expresses this relationship.

$$E = \int P(t)dt = \lim_{T \rightarrow 0} \left\{ \sum_{n=1}^{\infty} P(nT) \times T \right\} \tag{10}$$

where:

n is the discrete time-sampled number.

T is the sample period.

The discrete time sample period (*T*) for the accumulation registers in the ADE7953 is 4.83 μs (1/206.9 kHz). This is illustrated in Figure 46, which shows the energy register roll-over rates with full-scale inputs.

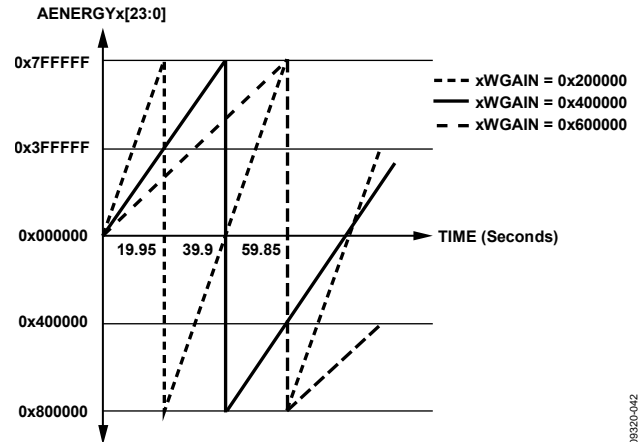

Figure 46. Energy Register Roll-Over Time for Active Energy

Note that the energy register contents roll over to full-scale negative (0x800000) and continue to increase in value when the power or energy flow is positive. Conversely, if the power is negative, the energy register underflows to full-scale positive (0x7FFFFFFF) and continues to decrease in value.

AENERGYA and AENERGYB are read-with-reset registers by default. This means that the contents of these registers are reset to 0 after a read operation. This feature can be disabled by clearing Bit 6 (RSTREAD) of the LCYCMODE register (Address 0x004).

The ADE7953 includes two sets of interrupts that are triggered when the active energy register is half full (positive or negative) or when an overflow or underflow condition occurs. The first set of interrupts is associated with the Current Channel A active energy, and the second set of interrupts is associated with the Current Channel B active energy. These interrupts are disabled by default and can be enabled by setting the AEHFA and AEOFA bits in the IRQENA register (Address 0x22C and Address 0x32C) for Current Channel A, and the AEHFB and AEOFB bits in the IRQENB register (Address 0x22F and Address 0x32F) for Current Channel B.

Active Energy Integration Time Under Steady Load

The discrete time sample period (*T*) for the accumulation registers is 4.83 μs (1/206.9 kHz). With full-scale sinusoidal signals on the analog inputs and the AWGAIN and BWGAIN registers set to 0x400000, a pulse is generated and added to the AENERGYA and AENERGYB registers every 4.83 μs. The maximum positive value that can be stored in the 24-bit AENERGYA and AENERGYB registers is 0x7FFFFFFF before the register overflows. The integration time under these conditions can be calculated as follows:

$$Time = 0x7FFFFFFF \times 4.83 \mu s = 40.5 \text{ sec} \tag{11}$$

Active Energy Line Cycle Accumulation Mode

In active energy line cycle accumulation mode, the energy accumulation of the ADE7953 is synchronized to the voltage channel zero crossing so that the active energy can be accumulated over an integral number of half line cycles. This feature is available for both Current Channel A and Current Channel B active energy. The advantage of summing the active energy over an integral number of half line cycles is that the sinusoidal component of the active energy is reduced to 0 (see Equation 12 to Equation 15). This eliminates any ripple in the energy calculation. Energy is calculated more accurately and in a shorter time because the integration period can be shortened. The line cycle accumulation mode can be used for fast calibration and also to obtain the average power over a specified time period. Using Equation 6, the following description of the energy accumulation can be derived:

$$P(t) = VI - [LPF] \times \cos(2\omega t) \tag{12}$$

$$E(t) = \int_0^{nT} VI dt - [LPF] \times \int_0^{nT} \cos(2\omega t) dt \tag{13}$$

where:

n is an integer.

T is the line cycle period.

Because the sinusoidal component is integrated over an integer number of line cycles, its value is always 0. Therefore,

$$E(t) = \int_0^{nT} VI dt + 0 \tag{14}$$

$$E = VInt \tag{15}$$

Line cycle accumulation mode is disabled by default and can be enabled on Current Channel A and Current Channel B by setting the ALWATT and BLWATT bits to 1 in the LCYCMODE register (Address 0x004). The accumulation time should be written to the LINECYC register (Address 0x101) in the unit of number of half line cycles. The ADE7953 can accumulate energy for up to 65,535 half line cycles. This equates to an accumulation period of approximately 655 sec with 50 Hz inputs and 546 sec with 60 Hz inputs.

The number of half line cycles written to the LINECYC register is used for both the Current Channel A and Current Channel B accumulation periods. At the end of a line cycle accumulation cycle, the AENERGYA and AENERGYB registers are updated, and the CYCEND flag is set in the IRQSTATA register (Address 0x22D and Address 0x32D). If the CYCEND bit in the IRQENA register is set, an external interrupt is issued on the IRQ pin. In this way, the IRQ pin can also be used to signal the completion of the line cycle accumulation. Another accumulation cycle begins immediately as long as the ALWATT and BLWATT bits in the LCYCMODE register remain set.

The contents of the AENERGYA and AENERGYB registers are updated synchronous to the CYCEND flag. The AENERGYA and AENERGYB registers hold their current values until the end of the next line cycle period, when the contents are replaced with the new reading. If the read-with-reset bit (RSTREAD) in the LCYCMODE register (Address 0x004) is set, the contents of the AENERGYA and AENERGYB registers are cleared after a read and remain at 0 until the end of the next line cycle period.

If a new value is written to the LINECYC register (Address 0x101) midway through a line cycle accumulation, the new value is not internally loaded until the end of a line cycle period. When the LINECYC register is updated mid-reading, the current energy accumulation cycle is completed, and the new value is then programmed, ready for the next cycle. This prevents any invalid readings due to changes to the LINECYC register (see Figure 47).

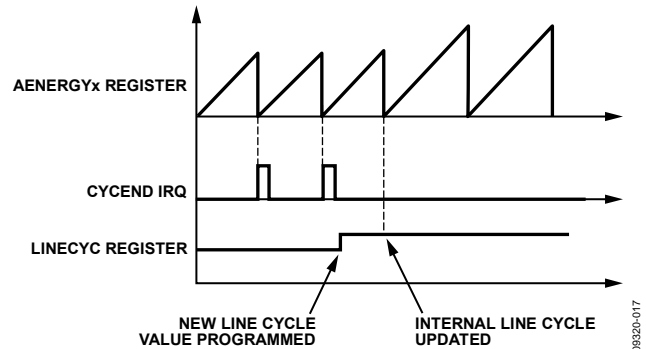

Figure 47. Changing the LINECYC Register

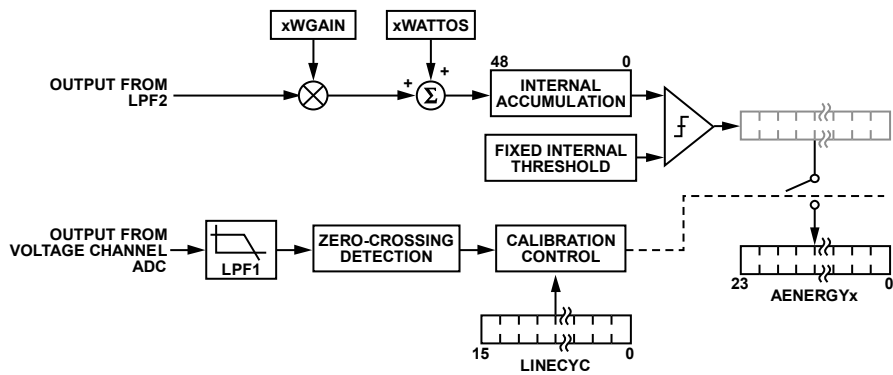

Figure 48. Active Energy Line Cycle Accumulation

Note that when line cycle accumulation mode is first enabled, the reading after the first CYCEND flag should be ignored because it may be inaccurate. This is because the line cycle accumulation mode is not synchronized to the zero crossing and, therefore, the first reading may not be over a complete number of half line cycles. After the first line cycle accumulation is complete, all successive readings will be correct.

ACTIVE ENERGY ACCUMULATION MODES

Signed Accumulation Mode

The default active energy accumulation mode for the ADE7953 is a signed accumulation based on the active power information.

Positive-Only Accumulation Mode

The ADE7953 includes a positive-only accumulation mode option for Current Channel A and Current Channel B active energy. In positive-only accumulation mode, the energy accumulation is done only for positive power, ignoring any occurrence of negative power above or below the no-load threshold (see Figure 49).

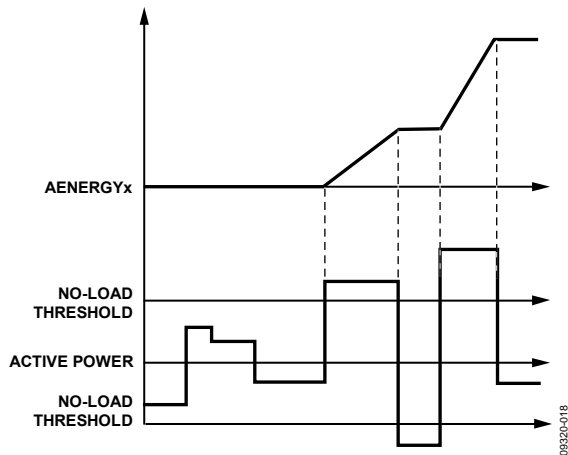

Figure 49. Positive-Only Accumulation Mode

The positive-only accumulation mode is disabled by default and can be enabled on Current Channel A and Current Channel B by setting the AWATTACC and BWATTACC bits to 01 in the ACCMODE register (Address 0x201 and Address 0x301).

If enabled, the positive-only accumulation mode affects both energy accumulation registers, AENERGYA and AENERGYB, as well as the CF output pins (see the Energy-to-Frequency Conversion section). Note that when the positive-only accumulation mode is enabled on a current channel, the reverse power feature is not available on that current channel (see the Reverse Power section).

Absolute Accumulation Mode

The ADE7953 includes an absolute energy accumulation mode for Current Channel A and Current Channel B active energy. In absolute accumulation mode, the energy accumulation is done using the absolute active power, ignoring any occurrences of energy below the no-load threshold (see Figure 50).

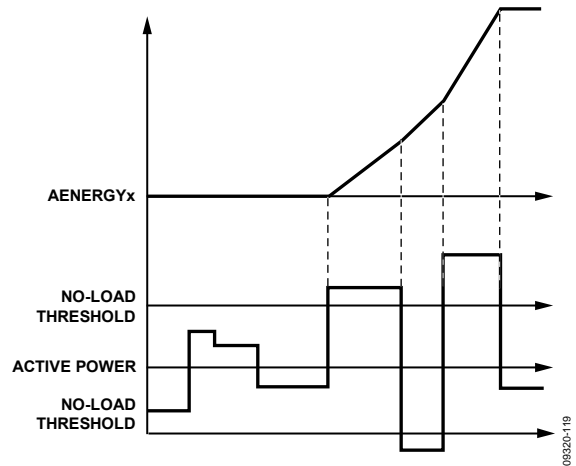

Figure 50. Active Energy Absolute Accumulation Mode

The absolute accumulation mode is disabled by default and can be enabled on Current Channel A and Current Channel B by setting the AWATTACC and BWATTACC bits to 10 in the ACCMODE register (Address 0x201 and Address 0x301).

If enabled, the absolute accumulation mode affects both energy accumulation registers, AENERGYA and AENERGYB, as well as the CF output pins (see the Energy-to-Frequency Conversion section). Note that when the absolute accumulation mode is enabled on a current channel, the reverse power feature is not available on that current channel (see the Reverse Power section).

REACTIVE POWER CALCULATION

Reactive power is defined as the product of the voltage and current waveforms when one of these signals is phase shifted by 90°. The resulting waveform is called the instantaneous reactive power signal.

Equation 16 provides an expression for the instantaneous reactive power signal in an ac system when the phase of the current channel is shifted by +90°.

$$RP(t) = V(t) \times I'(t) \tag{16}$$

$$RP(t) = VI \times \sin(\theta) + VI \times \sin(2\omega t + \theta) \tag{17}$$

$$V(t) = \sqrt{2} \times V \times \sin(\omega t + \theta) \tag{18}$$

$$I(t) = \sqrt{2} \times I \times \sin(\omega t) \tag{19}$$

$$I'(t) = \sqrt{2} \times I \times \sin\left(\omega t + \frac{\pi}{2}\right) \tag{20}$$

where:

V is the rms voltage.

I is the rms current.

θ is the phase difference between the voltage and current channel.

The average reactive power over an integral number of line cycles (n) is given by the expression in Equation 21.

$$RP = \frac{1}{nT} \int_0^{nT} RP(t) dt = VI \times \sin(\theta) \tag{21}$$

where:

RP is the reactive power.

T is the line cycle period.

The reactive power is equal to the dc component of the instantaneous reactive power signal ($RP(t)$ in Equation 16). This relationship is used to calculate reactive power in the ADE7953. The signal chain for the reactive power and energy calculations in the ADE7953 is shown in Figure 51.

The instantaneous reactive power signal $RP(t)$ is generated by multiplying the current signal and the voltage signal. Simultaneous calculations are performed using Current Channel A and Current Channel B. The multiplication is performed over the full 1.23 kHz bandwidth and results in a reactive power measurement that includes all harmonics included in this range.

The ADE7953 reactive power measurement is stable over the full frequency range. The dc component of the instantaneous reactive power signal is then extracted by a low-pass filter to obtain the reactive power information.

The frequency response of the LPFs in the reactive power signal paths is identical to the frequency response of the LPFs used in the active power calculation. Because the LPF does not have an ideal “brick wall” frequency response, the reactive power signal has some ripple associated with it. This ripple is sinusoidal and has a frequency equal to twice the line frequency. Because the ripple is sinusoidal in nature, it is removed when the reactive power signal is integrated to compute the reactive energy (see the Reactive Energy Calculation section).

The ADE7953 computes the reactive power simultaneously on Current Channel A and Current Channel B and stores the resulting measurements in the AVAR (Address 0x214 and Address 0x314) and BVAR (Address 0x215 and Address 0x315) registers, respectively. With full-scale inputs, the expected reading in the AVAR and BVAR registers is approximately 4862401 LSBs (decimal).

The reactive power registers are updated at a rate of 6.99 kHz and can be read using the waveform sampling mode (see the Instantaneous Powers and Waveform Sampling section).

SIGN OF REACTIVE POWER CALCULATION

The reactive power measurement in the ADE7953 is a signed calculation. If the current waveform is leading the voltage waveform, the reactive power is negative. Negative reactive power indicates a capacitive load. If the current waveform is lagging the voltage waveform, the reactive power is positive. Positive reactive power indicates an inductive load. The ACCMODE register (Address 0x201 and Address 0x301) includes two sign indication bits that show the sign of the reactive power of Current Channel A (VARSIGN_A) and Current Channel B (VARSIGN_B). See the Sign Indication section for more information.

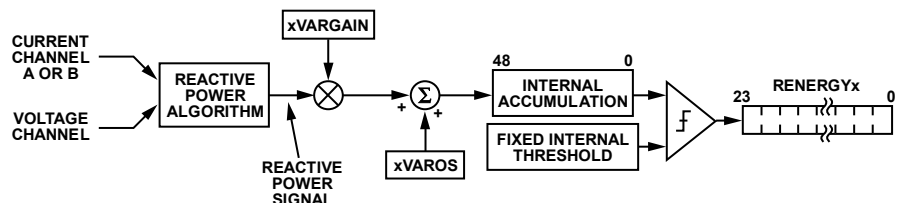

Figure 51. Reactive Energy Signal Chain

REACTIVE ENERGY CALCULATION

The ADE7953 achieves the integration of the reactive power signal in two stages. In the first stage, the reactive power signals are accumulated in an internal 48-bit register every 143 μs (6.99 kHz) until an internal fixed threshold is reached. When this threshold is reached, a pulse is generated and is accumulated in 24-bit, user-accessible accumulation registers. The internal threshold results in a maximum accumulation rate of approximately 206.9 kHz with full-scale inputs. This process occurs simultaneously on Current Channel A and Current Channel B, and the resulting readings can be read in the 24-bit RENERGYA (Address 0x220 and Address 0x320) and RENERGYB (Address 0x221 and Address 0x321) registers. Both stages of the accumulation are signed and, therefore, negative energy is subtracted from positive energy.

Note that the reactive energy register contents roll over to full-scale negative (0x800000) and continue to increase in value when the power or energy flow is positive. Conversely, if the power is negative, the energy register underflows to full-scale positive (0x7FFFFFFF) and continues to decrease in value.

RENERGYA and RENERGYB are read-with-reset registers by default. This means that the contents of these registers are reset to 0 after a read operation. This feature can be disabled by clearing Bit 6 (RSTREAD) of the LCYCMODE register (Address 0x004).

The ADE7953 includes two sets of interrupts that are triggered when the reactive energy register is half full (positive or negative) or when an overflow or underflow condition occurs. The first set of interrupts is associated with the Current Channel A reactive energy, and the second set of interrupts is associated with the Current Channel B reactive energy. These interrupts are disabled by default and can be enabled by setting the VAREHFA and VAREOFA bits in the IRQENA register (Address 0x22C and Address 0x32C) for Current Channel A, and the VAREHFB and VAREOFB bits in the IRQENB register (Address 0x22F and Address 0x32F) for Current Channel B.

Reactive Energy Integration Time Under Steady Load

The discrete time sample period (T) for the accumulation registers is 4.83 μs (1/206.9 kHz). With full-scale sinusoidal signals on the analog inputs and a phase shift of 90°, a pulse is generated and added to the RENERGYA and RENERGYB registers every 4.83 μs, assuming that the AVARGAIN and BVARGAIN registers are set to 0x00. The maximum positive value that can be stored in the 24-bit RENERGYA and RENERGYB registers is 0x7FFFFFFF before the register overflows. The integration time under these conditions can be calculated as follows:

$$Time = 0x7FFFFFFF \times 4.83 \mu s = 40.5 \text{ sec} \tag{22}$$

Reactive Energy Line Cycle Accumulation Mode

In reactive energy line cycle accumulation mode, the energy accumulation of the ADE7953 is synchronized to the voltage channel zero crossing so that the reactive energy on Current Channel A and Current Channel B can be accumulated over an integral number of half line cycles. Line cycle accumulation mode is disabled by default and can be enabled on Current Channel A and Current Channel B by setting the ALVAR and BLVAR bits to 1 in the LCYCMODE register (Address 0x004).

The accumulation time should be written to the LINECYC register (Address 0x101) in the unit of number of half line cycles. The number of half line cycles written to the LINECYC register is used for both the Current Channel A and Current Channel B accumulation periods. The ADE7953 can accumulate reactive energy for up to 65,535 half line cycles. This equates to an accumulation period of approximately 655 sec with 50 Hz inputs and 546 sec with 60 Hz inputs.

At the end of a line cycle accumulation cycle, the RENERGYA and RENERGYB registers are updated, and the CYCEND flag in the IRQSTATA register (Address 0x22D and Address 0x32D) is set. If the CYCEND bit in the IRQENA register is set, an external interrupt is issued on the IRQ pin. In this way, the IRQ pin can also be used to signal the completion of the line cycle accumulation. Another accumulation cycle begins immediately as long as the ALVAR and BLVAR bits in the LCYCMODE register remain set.

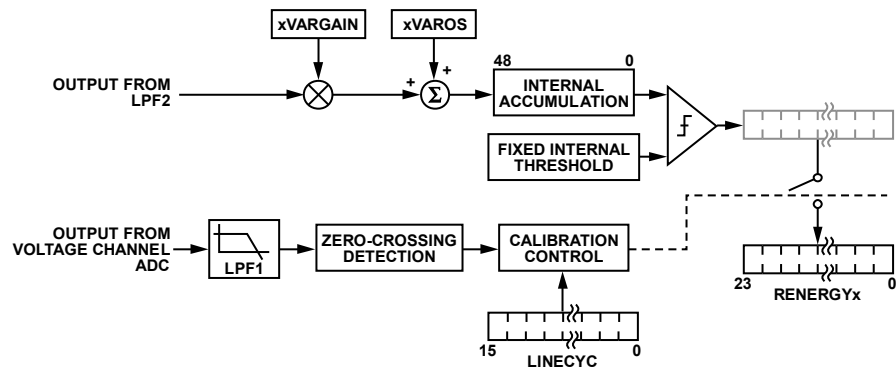

Figure 52. Reactive Energy Line Cycle Accumulation

The contents of the RENERGYA and RENERGYB registers are updated synchronous to the CYCEND flag. The RENERGYA and RENERGYB registers hold their current values until the end of the next line cycle period, when the contents are replaced with the new reading. If the read-with-reset bit (RSTREAD) in the LCYCMODE register (Address 0x004) is set, the contents of the RENERGYA and RENERGYB registers are cleared after a read and remain at 0 until the end of the next line cycle period.

If a new value is written to the LINECYC register (Address 0x101) midway through a line cycle accumulation, the new value is not internally loaded until the end of a line cycle period. When the LINECYC register is updated mid-reading, the current energy accumulation cycle is completed, and the new value is then programmed, ready for the next cycle. This prevents any invalid readings due to changes to the LINECYC register (see Figure 47).

Note that when line cycle accumulation mode is first enabled, the reading after the first CYCEND flag should be ignored because it may be inaccurate. This is because the line cycle accumulation mode is not synchronized to the zero crossing and, therefore, the first reading may not be over a complete number of half line cycles. After the first line cycle accumulation is complete, all successive readings will be correct.

REACTIVE ENERGY ACCUMULATION MODES

Signed Accumulation Mode

The default reactive energy accumulation mode for the ADE7953 is a signed accumulation based on the reactive power information.

Antitamper Accumulation Mode

The ADE7953 includes an antitamper accumulation mode that accumulates reactive energy depending on the sign of the active power. When the active power is positive, the reactive power is added to the reactive energy accumulation register. When the active power is negative, the reactive power is subtracted from the reactive energy accumulation register (see Figure 53).

Antitamper accumulation mode is disabled by default and can be enabled on Current Channel A and Current Channel B by setting the AVARACC and BVARACC bits to 01 in the ACCMODE register (Address 0x201 and Address 0x301). If enabled, the antitamper accumulation mode affects both reactive energy accumulation registers, RENERGYA and RENERGYB, as well as the CF output pins (see the Energy-to-Frequency Conversion section).

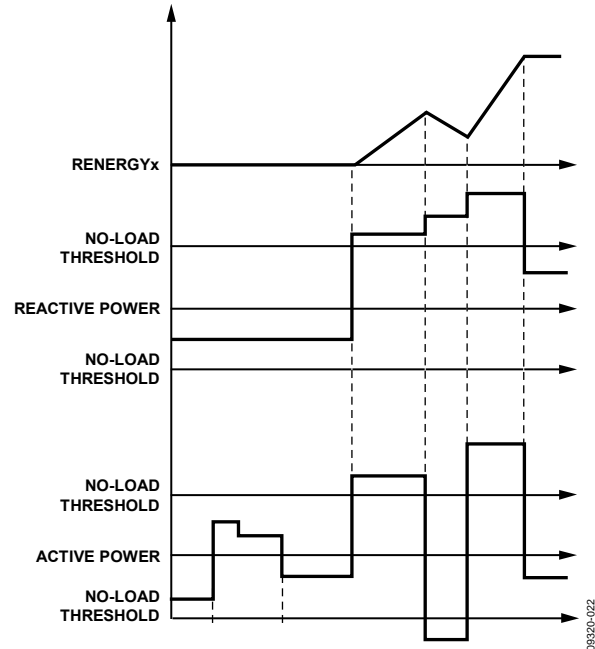

Figure 53. Reactive Energy Accumulation in Antitamper Accumulation Mode

Absolute Accumulation Mode

The ADE7953 includes an absolute energy accumulation mode for Current Channel A and Current Channel B reactive energy. In absolute accumulation mode, the energy accumulation is done using the absolute reactive power, ignoring any occurrences of energy below the no-load threshold (see Figure 54).

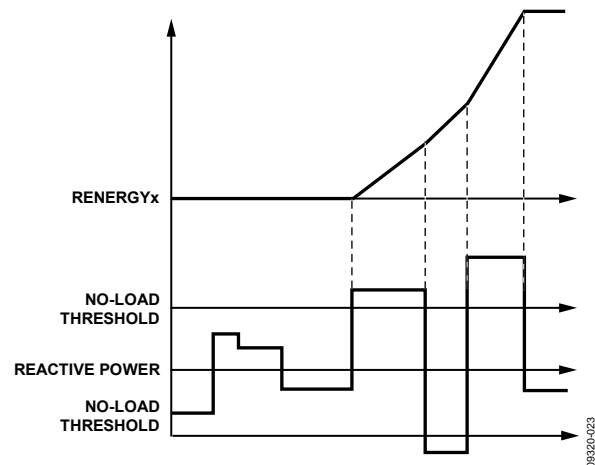

Figure 54. Reactive Energy Absolute Accumulation Mode

The absolute accumulation mode is disabled by default and can be enabled on Current Channel A and Current Channel B by setting the AVARACC and BVARACC bits to 10 in the ACCMODE register (Address 0x201 and Address 0x301).

If enabled, the absolute accumulation mode affects both energy accumulation registers, RENERGYA and RENERGYB, as well as the CF output pins (see the Energy-to-Frequency Conversion section).

APPARENT POWER CALCULATION

Apparent power is defined as the maximum power that can be delivered to a load. VRMS and IRMS are the effective voltage and current delivered to the load, respectively. The apparent power can, therefore, be defined as the product of VRMS and IRMS. This relationship is independent of the phase angle between the voltage and current.

Equation 26 provides an expression for the instantaneous apparent power signal in an ac signal.

$$V(t) = \sqrt{2} \times VRMS \times \sin(\omega t) \tag{23}$$

$$I(t) = \sqrt{2} \times IRMS \times \sin(\omega t + \theta) \tag{24}$$

$$P(t) = V(t) \times I(t) \tag{25}$$

$$P(t) = VRMS \times IRMS \times \cos(\theta) - VRMS \times IRMS \times \cos(2\omega t + \theta) \tag{26}$$

The ADE7953 computes the apparent power simultaneously on Current Channel A and Current Channel B and stores the resulting measurements in the AVA (Address 0x210 and Address 0x310) and BVA (Address 0x211 and Address 0x311) registers, respectively.

The apparent power measurement is taken over a bandwidth of 1.23 kHz and includes the effects of any harmonics within that range. The apparent power registers are updated at a rate of 6.99 kHz and can be read using the waveform sampling mode (see the Instantaneous Powers and Waveform Sampling section).

APPARENT ENERGY CALCULATION

The apparent energy is given as the integral of the apparent power.

$$Apparent\ Energy = \int Apparent\ Power(t)dt \tag{27}$$

The ADE7953 achieves the integration of the apparent power signal in two stages. In the first stage, the apparent power signals are accumulated in an internal 48-bit register every 143 μs (6.99 kHz) until an internal fixed threshold is reached. When this threshold is reached, a pulse is generated and is accumulated in 24-bit, user accessible accumulation registers. The internal threshold results in a maximum accumulation rate of approximately 206.9 kHz with full-scale inputs.

This process occurs simultaneously on Current Channel A and Current Channel B, and the resulting readings can be read in the 24-bit APENERGYA (Address 0x222 and Address 0x322) and APENERGYB (Address 0x223 and Address 0x323) registers.

Note that the apparent energy register contents roll over to full-scale negative (0x800000) and continue to increase in value when the power or energy flow is positive. Conversely, if the power is negative, the energy register underflows to full-scale positive (0x7FFFFFFF) and continues to decrease in value.

APENERGYA and APENERGYB are read-with-reset registers by default. This means that the contents of these registers are reset to 0 after a read operation. This feature can be disabled by clearing Bit 6 (RSTREAD) of the LCYCMODE register (Address 0x004).

The ADE7953 includes two sets of interrupts that are triggered when the apparent energy register is half full (positive or negative) or when an overflow or underflow condition occurs. The first set of interrupts is associated with the Current Channel A apparent energy, and the second set of interrupts is associated with the Current Channel B apparent energy.

These interrupts are disabled by default and can be enabled by setting the VAEHFA and VAEOFA bits in the IRQENA register (Address 0x22C and Address 0x32C) for Current Channel A, and the VAEHFB and VAEOFB bits in the IRQENB register (Address 0x22F and Address 0x32F) for Current Channel B.

Apparent Energy Integration Time Under Steady Load

The discrete time sample period (T) for the accumulation registers is 4.83 μs (1/206.9 kHz). With full-scale sinusoidal signals on the analog inputs, a pulse is generated and added to the APENERGYA and APENERGYB registers every 4.83 μs, assuming that the AVAGAIN and BVAGAIN registers are set to 0x00. The maximum positive value that can be stored in the 24-bit APENERGYA and APENERGYB registers is 0x7FFFFFFF before the register overflows. The integration time under these conditions can be calculated as follows:

$$Time = 0x7FFFFFFF \times 4.83 \mu s = 40.5 \text{ sec} \tag{28}$$

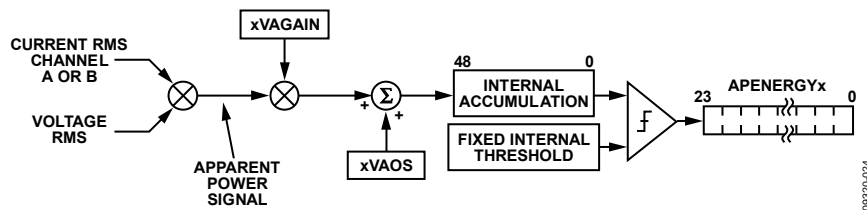

Figure 55. Apparent Energy Accumulation Signal Chain

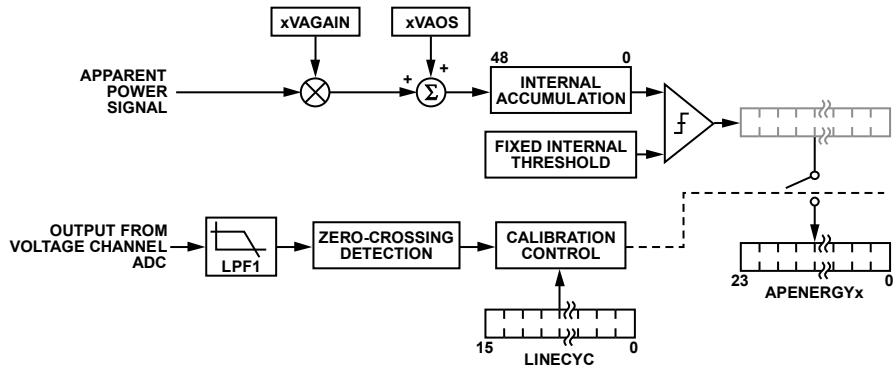

Figure 56. Apparent Energy Line Cycle Accumulation

Apparent Energy Line Cycle Accumulation Mode

In apparent energy line cycle accumulation mode, the energy accumulation of the ADE7953 is synchronized to the voltage channel zero crossing so that the apparent energy on Current Channel A and Current Channel B can be accumulated over an integral number of half line cycles. Line cycle accumulation mode is disabled by default and can be enabled on Current Channel A and Current Channel B by setting the ALVA and BLVA bits to 1 in the LCYCMODE register (Address 0x004).

The accumulation time should be written to the LINECYC register (Address 0x101) in the unit of number of half line cycles. The number of half line cycles written to the LINECYC register is used for both the Current Channel A and Current Channel B accumulation periods. The ADE7953 can accumulate apparent energy for up to 65,535 half line cycles. This equates to an accumulation period of approximately 655 sec with 50 Hz inputs and 546 sec with 60 Hz inputs.

At the end of a line cycle accumulation cycle, the APENERGYA and APENERGYB registers are updated, and the CYCEND flag in the IRQSTATA register (Address 0x22D and Address 0x32D) is set. If the CYCEND bit in the IRQENA register is set, an external interrupt is issued on the $\overline{\text{IRQ}}$ pin. In this way, the $\overline{\text{IRQ}}$ pin can also be used to signal the completion of the line cycle accumulation. Another accumulation cycle begins immediately, as long as the ALVA and BLVA bits in the LCYCMODE register remain set.

The contents of the APENERGYA and APENERGYB registers are updated synchronous to the CYCEND flag. The APENERGYA and APENERGYB registers hold their current values until the end of the next line cycle period, when the contents are replaced with the new reading. If the read-with-reset bit (RSTREAD) in the LCYCMODE register (Address 0x004) is set, the contents of the APENERGYA and APENERGYB registers are cleared after a read and remain at 0 until the end of the next line cycle period.

If a new value is written to the LINECYC register (Address 0x101) midway through a line cycle accumulation, the new value is not internally loaded until the end of a line cycle period. When the LINECYC register is updated mid-reading, the current energy accumulation cycle is completed, and the new value is then programmed, ready for the next cycle. This prevents any invalid readings due to changes to the LINECYC register (see Figure 47).

Note that when line cycle accumulation mode is first enabled, the reading after the first CYCEND flag should be ignored because it may be inaccurate. This is because the line cycle accumulation mode is not synchronized to the zero crossing and, therefore, the first reading may not be over a complete number of half line cycles. After the first line cycle accumulation is complete, all successive readings will be correct.

AMPERE-HOUR ACCUMULATION

In a tampering situation where no voltage is available to the energy meter, the ADE7953 can accumulate the ampere-hour measurement instead of the apparent power in the APENERGYA and APENERGYB registers. If enabled, the Current Channel A and Current Channel B IRMS measurements are continually accumulated instead of the apparent power. If enabled, the apparent power CF output pin also reflects the ampere-hour measurement (see the Energy-to-Frequency Conversion section). All the signal processing and calibration registers available for the apparent power and apparent energy accumulation remain active when the ampere-hour accumulation mode is enabled. This includes the apparent energy no-load feature (see the Apparent Energy No-Load section). Recalibration is required in this mode due to internal scaling differences between the IRMS and apparent signals.

ENERGY-TO-FREQUENCY CONVERSION

The ADE7953 provides two energy-to-frequency conversions for calibration purposes. After initial calibration at manufacturing, the manufacturer or end customer is often required to verify the meter accuracy. One convenient way to do this is to provide an output frequency that is proportional to the active, reactive, or apparent power, or to the current rms under steady load conditions. This output frequency provides a simple single-wire interface that can be optically isolated to interface to external calibration equipment. The ADE7953 includes two fully programmable calibration frequency output pins: CF1 (Pin 23) and CF2 (Pin 24). The energy-to-frequency conversion is illustrated in Figure 57.

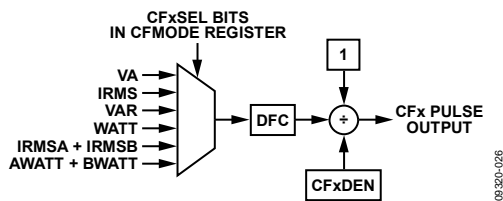

Figure 57. Energy-to-Frequency Conversion

Two digital-to-frequency converters (DFCs) are used to generate the pulse outputs. The DFC generates a pulse each time ± 1 LSB is accumulated in the energy register. An output pulse is generated when CFxDEN number of pulses is generated at the DFC output.

The CF1 and CF2 pins can be configured to output a signal that is proportional to the active power, reactive power, apparent power, or IRMS on Current Channel A or Current Channel B. In addition, it is possible to configure CF1 and CF2 to output a signal that is proportional to the sum of the Current Channel A IRMS and the Current Channel B IRMS, or, alternatively, proportional to the sum of the active power on Current Channel A and the active power on Current Channel B. Recalibration is required in this configuration because the actual CF output equals the sum of the active power on Current Channel A and the active power on Current Channel B, divided by 2. The CF1 and CF2 output pins are programmed by setting the CF1SEL and CF2SEL bits in the CFMODE register (Address 0x107).

Both pulse outputs (CF1 and CF2) are disabled by default and can be enabled by clearing the CF1DIS and CF2DIS bits, respectively, in the CFMODE register (Address 0x107).

PULSE OUTPUT CHARACTERISTICS

The pulse outputs for both DFCs stay low for 80 ms if the pulse period is longer than 160 ms (6.25 Hz). If the pulse period is shorter than 160 ms, the duty cycle of the pulse outputs is 50%. The pulse outputs are active low. The maximum output frequency with ac inputs at full scale and with CFxDEN = 0x00 is approximately 206.9 kHz.

The ADE7953 includes two unsigned 16-bit registers, CF1DEN (Address 0x103) and CF2DEN (Address 0x104) that control the CF output frequency on the CF1 and CF2 pins, respectively. The 16-bit frequency scaling registers can scale the output frequency by $1/(2^{16} - 1)$ to 1 with a step of $1/(2^{16} - 1)$. Note that when modifying the CF1DEN and CF2DEN registers, two sequential write operations must be performed to ensure that the write is successful.

ENERGY CALIBRATION

GAIN CALIBRATION

The active, reactive, and apparent power measurements can be calibrated on Current Channel A and Current Channel B separately. This allows meter-to-meter gain variation to be compensated for.

The AWGAIN register (Address 0x282 and Address 0x382) controls the active power gain calibration on Current Channel A, and the BWGAIN register (Address 0x28E and Address 0x38E) controls the active power gain calibration on Current Channel B. The default value of the xWGAIN registers is 0x400000, which corresponds to no gain calibration. The minimum value that can be written to the xWGAIN registers is 0x200000, which represents a gain adjustment of -50%. The maximum value that can be written to the xWGAIN registers is 0x600000, which represents a gain adjustment of +50%. Equation 29 shows the relationship between the gain adjustment and the xWGAIN registers.

$$\begin{aligned} \text{Output Power (W)} = & \quad (29) \\ \text{Active Power} \times & \left(\frac{xWGAIN}{0x400000} \right) \end{aligned}$$

Similar gain calibration registers are available for the reactive power and the apparent power. The reactive power on Current Channel A and Current Channel B can be gain calibrated using the AVARGAIN (Address 0x283 and Address 0x383) and BVARGAIN (Address 0x28F and Address 0x38F) registers, respectively. The apparent power on Current Channel A and Current Channel B can be gain calibrated using the AVAGAIN (Address 0x284 and Address 0x384) and BVAGAIN (Address 0x290 and Address 0x390) registers, respectively. The xVARGAIN and xVAGAIN registers affect the reactive and apparent powers in the same way that the xWGAIN registers affect the active power. Equation 29 can therefore be modified to represent the gain calibration of the reactive and apparent powers, as shown in Equation 30 and Equation 31.

$$\begin{aligned} \text{Output Power (VAR)} = & \quad (30) \\ \text{Reactive Power} \times & \left(\frac{xVARGAIN}{0x400000} \right) \end{aligned}$$

$$\begin{aligned} \text{Output Power (VA)} = & \quad (31) \\ \text{Apparent Power} \times & \left(\frac{xVAGAIN}{0x400000} \right) \end{aligned}$$

Current Channel Gain Adjustment

A gain calibration register is also provided on Current Channel B. This register can be used to match Current Channel B to Current Channel A for simple calibration and computation. The Current Channel B gain calibration is performed using the BIGAIN register (Address 0x28C and Address 0x38C). Equation 32 shows the relationship between the gain adjustment and the IRMSB register.

$$\begin{aligned} IRMSB_{Expected} = & \quad (32) \\ IRMSB_{INITIAL} \times & \left(\frac{BIGAIN}{0x400000} \right) \end{aligned}$$

Similar registers are available for the voltage channel and for Current Channel A. The VGAIN register (Address 0x281 and Address 0x381) and the AIGAIN register (Address 0x280 and Address 0x380) provide the calibration adjustment and function in the same way as the BIGAIN register.

PHASE CALIBRATION

The ADE7953 is designed to function with a variety of current transducers, including those that induce inherent phase errors. A phase error of 0.1° to 0.3° is not uncommon for a current transformer (CT). These phase errors can vary from part to part, and they must be corrected to achieve accurate power readings. The errors associated with phase mismatch are particularly noticeable at low power factors. The ADE7953 provides a means of digitally calibrating these small phase errors by introducing a time delay or a time advance.

Because different sensors can be used on Current Channel A and Current Channel B, separate phase calibration registers are included on each channel. The PHCALA register (Address 0x108) can be used to correct phase errors on Current Channel A, and the PHCALB register (Address 0x109) can be used to correct phase errors on Current Channel B. Both registers are in 10-bit sign magnitude format, with the MSB indicating whether a time delay or a time advance is added to the corresponding current channel. Writing a 0 to the MSB of the PHCALx register introduces a time delay to the current channel. Writing a 1 to the MSB of the PHCALx register introduces a time advance.

The maximum range that can be written to PHCALx[8:0] is 383 (decimal). One LSB of the PHCALx register is equivalent to a time delay or time advance of 1.117 μs (CLKIN/4). With a line frequency of 50 Hz, the resolution is 0.02°/LSB ((360 × 50 Hz)/895 kHz), which provides a total correction of 7.66° in either direction. With a line frequency of 60 Hz, the resolution is 0.024°/LSB ((360 × 60 Hz)/895 kHz), which provides a total correction of 9.192° in either direction.

OFFSET CALIBRATION

Power Offsets

The ADE7953 includes offset calibration registers for the active, reactive, and apparent powers on Current Channel A and Current Channel B. Offsets can exist in the power calculations due to crosstalk between channels on the PCB and in the ADE7953. The offset calibration allows these offsets to be removed to increase the accuracy of the measurement at low input levels.

The active power offset can be corrected on Current Channel A and Current Channel B by adjusting the AWATTOS (Address 0x289 and Address 0x389) and BWATTOS (Address 0x295 and Address 0x395) registers, respectively. The xWATTOS registers are 24-bit, signed twos complement registers with default values of 0. One LSB in the xWATTOS register is equivalent to 0.001953 LSBs in the active power measurement. The xWATTOS value is, therefore, applied to the xWATT register, shifted by nine bits, as shown in Figure 58.

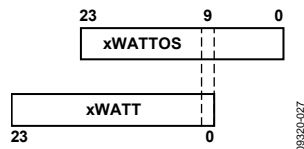

Figure 58. xWATTOS and xWATT Registers

With full-scale inputs on the voltage and current channels, the expected power reading is approximately 4862401 LSBs (decimal). At -60 dB (1000:1) on Current Channel A and Current Channel B, the expected readings in the AWATT and BWATT registers, respectively, are approximately 4862 (decimal). One LSB of the xWATT register, therefore, corresponds to 0.000039% at -60 dB.

The reactive power offset can be corrected on Current Channel A and Current Channel B by adjusting the AVAROS (Address 0x28A and Address 0x38A) and BVAROS (Address 0x296 and Address 0x396) registers, respectively. The xVAROS registers affect the reactive power in the same way that the xWATTOS registers affect the active power.

The apparent power offset can be corrected on Current Channel A and Current Channel B by adjusting the AVAOS (Address 0x28B and Address 0x38B) and BVAOS (Address 0x297 and Address 0x397) registers, respectively. The xVAOS registers affect the apparent power in the same way that the xWATTOS registers affect the active power.

RMS Offsets

The ADE7953 includes offset calibration registers to allow offset in the rms measurements to be corrected. Offset calibration registers are available for the IRMS measurements on Current Channel A and Current Channel B, as well as for the VRMS measurement. Offset can exist in the rms calculation due to input noise that is integrated in the dc component of $V^2(t)$. The offset calibration allows these offsets to be removed to increase the accuracy of the measurement at low input levels.

The voltage rms offset can be corrected by adjusting the VRMSOS register (Address 0x288 and Address 0x388). This 24-bit, signed twos complement register has a default value of 0, indicating that no offset is added. The VRMSOS value is applied prior to the square root function. Equation 33 shows the effect of the VRMSOS register on the VRMS measurement.

$$VRMS = \sqrt{VRMS_0^2 + VRMSOS \times 2^{12}} \quad (33)$$

where $VRMS_0$ is the initial VRMS reading prior to offset calibration.

The current rms offset is calibrated in a similar way. The AIRMSOS register (Address 0x286 and Address 0x386) compensates for offsets in the IRMSA measurement, and the BIRMSOS register (Address 0x292 and Address 0x392) compensates for offsets in the IRMSB measurement. Both registers are 24-bit, signed twos complement registers. The xIRMSOS registers affect the IRMS measurements in the same way that the VRMSOS register affects the VRMS measurement. Equation 33 can therefore be modified to represent the offset calibration on the IRMS, as shown in Equation 34 and Equation 35.

$$IRMSA = \sqrt{IRMSA_0^2 + AIRMSOS \times 2^{12}} \quad (34)$$

$$IRMSB = \sqrt{IRMSB_0^2 + BIRMSOS \times 2^{12}} \quad (35)$$

PERIOD MEASUREMENT

The ADE7953 provides a period measurement of the voltage channel. This measurement is provided in the 16-bit, unsigned period register (Address 0x10E). The period register is updated once every line period and has a settling time of 30 ms to 40 ms associated with it before the period measurement is stable.

The period measurement has a resolution of 4.48 $\mu\text{s}/\text{LSB}$ (223 kHz clock), which represents 0.0224% when the line frequency is 50 Hz and 0.0268% when the line frequency is 60 Hz.

The value of the period register for a 50 Hz network is approximately 4460 in decimal (223 kHz/50 Hz) and 3716 in decimal (223 kHz/60 Hz) for a 60 Hz network. The period register is stable at ± 1 LSB when the line is established and the measurement does not change.

The following equation can be used to compute the line period and frequency using the period register:

$$T_L = \frac{\text{PERIOD}[15:0] + 1}{223 \text{ kHz}} \text{ sec} \quad (36)$$

INSTANTANEOUS POWERS AND WAVEFORM SAMPLING

The ADE7953 provides access to the current and voltage channel waveform data, along with the instantaneous active, reactive, and apparent powers. This information allows the instantaneous data to be analyzed in more detail, including reconstruction of the current and voltage input for harmonic analyses. These measurements are available from a set of 24-bit/32-bit signed registers (see Table 7).

All measurements are updated at a rate of 6.99 kHz (CLKIN/512). The ADE7953 provides an interrupt status bit, WSMP, that is triggered at a rate of 6.99 kHz, allowing measurements to be synchronized with the instantaneous signal update rate. This status bit is available in the IRQSTATA register (Address 0x22D and Address 0x32D). This signal can also be configured to trigger an interrupt on the external $\overline{\text{IRQ}}$ pin by setting the WSMP bit (Bit 17) in the IRQENA register (Address 0x22C and Address 0x32C).

The ADE7953 also provides the option of issuing an unlatched, data-ready signal at the same rate of 6.99 kHz. This signal provides the same information as the WSMP interrupt, but it is unlatched and, therefore, does not need to be serviced each time that new data is available. The data-ready signal goes high for a period of 280 ns before automatically returning low. The data-ready signal is disabled by default and can be output on the REVP, ZX, and ZX_I pins by setting the REVP_ALT, ZX_ALT, and ZXI_ALT bits to 1001 in the ALT_OUTPUT register (Address 0x110).

Table 7. Waveform Sampling Registers

| Measurement | Register | Address | |
|------------------------------------|----------|---------|--------|
| | | 24-Bit | 32-Bit |
| Active power (Current Channel A) | AWATT | 0x212 | 0x312 |
| Active power (Current Channel B) | BWATT | 0x213 | 0x313 |
| Reactive power (Current Channel A) | AVAR | 0x214 | 0x314 |
| Reactive power (Current Channel B) | BVAR | 0x215 | 0x315 |
| Apparent power (Current Channel A) | AVA | 0x210 | 0x310 |
| Apparent power (Current Channel B) | BVA | 0x211 | 0x311 |
| Current (Current Channel A) | IA | 0x216 | 0x316 |
| Current (Current Channel B) | IB | 0x217 | 0x317 |
| Voltage (voltage channel) | V | 0x218 | 0x318 |

POWER FACTOR

The ADE7953 provides a direct power factor measurement simultaneously on Current Channel A and Current Channel B. Power factor in an ac circuit is defined as the ratio of the active power flowing to the load to the apparent power. The power factor measurement is defined in terms of “leading” or “lagging” referring to whether the current waveform is leading or lagging the voltage waveform.

When the current waveform is leading the voltage waveform, the load is capacitive and is defined as a negative power factor. When the current waveform is lagging the voltage waveform, the load is inductive and is defined as a positive power factor.

The relationship of the current waveform to the voltage waveform is illustrated in Figure 59.

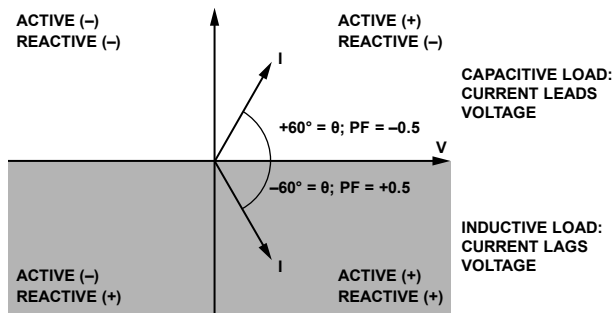

Figure 59. Capacitive and Inductive Loads

As shown in Figure 59, the reactive power measurement is negative when the load is capacitive and positive when the load is inductive. The sign of the reactive power can therefore be used to reflect the sign of the power factor.

The mathematical definition of power factor is shown in Equation 37.

$$\text{Power Factor} = (\text{Sign of Reactive Power}) \times \frac{\text{Active Power}}{\text{Apparent Power}} \quad (37)$$

The power factor measurement includes the effect of all harmonics over the 1.23 kHz bandwidth.

The power factor readings are stored in two 16-bit, signed registers: PFA (Address 0x10A) for Current Channel A and PFB (Address 0x10B) for Current Channel B. These registers are signed, twos complement registers with the MSB indicating the polarity of the power factor. Each LSB of the PFx register equates to a weight of 2^{-15} ; therefore, the maximum register value of 0x7FFF corresponds to a power factor value of 1. The minimum register value of 0x8000 corresponds to a power factor of -1.

By default, the instantaneous active and apparent power readings are used to calculate the power factor, and the register is updated at a rate of 6.99 kHz. The sign bit is taken from the instantaneous reactive energy measurement on each channel.

USING THE LINE CYCLE ACCUMULATION MODE TO DETERMINE THE POWER FACTOR

If a power factor measurement with more averaging is required, the ADE7953 can use the line cycle accumulation measurement on the active and apparent energies to determine the power factor (see the Active Energy Line Cycle Accumulation Mode section and the Apparent Energy Line Cycle Accumulation Mode section). This option provides a more stable power factor reading.

To use the line cycle accumulation mode to determine the power factor, the ADE7953 must be configured as follows:

- The PFMODE bit (Bit 3) must be set to 1 in the CONFIG register (Address 0x102).
- The line cycle accumulation mode must be enabled on both the active and apparent energies by setting the xLWATT and xLVA bits to 1 in the LCYCMODE register (Address 0x004).

When using line cycle accumulation to determine the power factor, the update rate of the power factor measurement is an integral number of half line cycles. The number of half line cycles is programmed in the LINECYC register (Address 0x101). For complete information about setting up the line cycle accumulation mode, see the Active Energy Line Cycle Accumulation Mode section and the Apparent Energy Line Cycle Accumulation Mode section.

POWER FACTOR WITH NO-LOAD DETECTION

The power factor measurement is affected by the no-load condition if no-load detection is enabled (see the No-Load Detection section). The following considerations apply only when no-load detection is enabled and a no-load condition occurs:

- If the apparent energy no-load condition is true, the power factor measurement is set to 1 because it is assumed that there is no active or reactive power.
- If the active energy no-load condition is true, the power factor measurement is set to 0 because it is assumed that the load is purely capacitive or inductive.
- If the reactive energy no-load condition is true, the sign of the power factor is based on the sign of the active power.

ANGLE MEASUREMENT

The ADE7953 can measure the time delay between the current and voltage inputs. This feature is available on both Current Channel A and Current Channel B. The negative-to-positive transitions identified by the zero-crossing detection circuit are used as a start and stop for the measurement (see Figure 60).

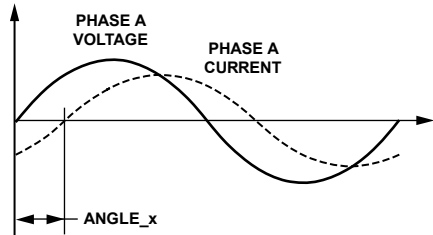

Figure 60. Current-to-Voltage Time Delay

The ADE7953 provides a time delay measurement on Current Channel A and Current Channel B simultaneously. The resulting measurements are available in the 16-bit, signed registers ANGLE_A (Address 0x10C) and ANGLE_B (Address 0x10D). One LSB of the ANGLE_A or ANGLE_B register corresponds to 4.47 μ s (223 kHz clock). This results in a resolution of 0.0807° at 50 Hz ((360 \times 50)/223 kHz) and 0.0969° at 60 Hz ((360 \times 60)/223 kHz).

The time delay between the current and voltage inputs can be used to characterize how balanced the load is. The delays between phase voltages and currents can be used to compute the power factor on Current Channel A and Current Channel B, respectively, as shown in Equation 38.

$$\cos \phi_x = \cos \left(ANGLE_x \times \frac{360^\circ \times f_{LINE}}{223 \text{ kHz}} \right) \quad (38)$$

where:

$x = A$ or B .

f_{LINE} is 50 Hz or 60 Hz.

This method of determining the power factor does not take into account the effect of any harmonics. Therefore, it may not be equal to the true definition of power factor shown in Equation 37.

NO-LOAD DETECTION

The ADE7953 includes a no-load detection feature that eliminates “meter creep.” Meter creep is defined as excess energy that is accumulated by the meter when there is no load attached. The ADE7953 warns of this condition and stops energy accumulation if the energy falls below a programmable threshold. The ADE7953 includes a no-load feature on the active, reactive, and apparent energy measurements. This allows a true no-load condition to be detected and also prevents creep in purely resistive, inductive, or capacitive load conditions. The no-load feature is enabled by default.

SETTING THE NO-LOAD THRESHOLDS

Three separate 24-/32-bit registers are available to set the no-load threshold on the active, reactive, and apparent energies: AP_NOLOAD (Address 0x203 and Address 0x303), VAR_NOLOAD (Address 0x204 and Address 0x304), and VA_NOLOAD (Address 0x205 and Address 0x305). The active, reactive, and apparent energy no-load thresholds are completely independent and, therefore, all three thresholds are required. The no-load thresholds for all three measurements can be set based on Equation 39.

$$X_NOLOAD = 65,536 - \frac{Y}{1.4} \quad (39)$$

where:

X is AP, VAR, or VA.

Y is the required threshold amplitude with reference to full-scale energy (for example 20,000:1).

As shown in Equation 39, the no-load threshold can be configured based on the required level with respect to full scale. For example, if a no-load threshold of 10,000:1 of the full-scale current channel is required and the voltage channel is set up to operate at ± 250 mV (50% of full scale), then a value of 20,000 is required for Y. A default value of 58,393 (decimal) is programmed into the AP_NOLOAD and VAR_NOLOAD registers, setting the initial no-load threshold to approximately 10,000:1. The VA_NOLOAD register has a default value of 0x00.

The no-load thresholds AP_NOLOAD, VAR_NOLOAD, and VA_NOLOAD must be written before enabling the no-load feature. The no-load feature is enabled using the DISNOLOAD register (Address 0x001). If the threshold requires modification, disable the no-load detection, modify the threshold, and then reenables the feature using the DISNOLOAD register.

Although separate no-load interrupts are available for Current Channel A and Current Channel B (phase and neutral current), the same no-load level is used for both. For example, if the VAR_NOLOAD level is set to 0.05% of full scale, this value is the reactive power no-load threshold used for both Current Channel A (phase) and Current Channel B (neutral).

ACTIVE ENERGY NO-LOAD DETECTION

Active energy no-load detection can be used in conjunction with reactive energy no-load detection to establish a “true” no-load feature. If both the active and reactive energy fall below the no-load threshold, there is no resistive, inductive, or capacitive load. The active energy no-load feature can also be used to prevent creep of the active energy when there is an inductive or capacitive load present.

If the active energy on either Current Channel A (phase) or Current Channel B (neutral) falls below the programmed threshold, the active energy on that channel ceases to accumulate in the AENERGYA and AENERGYB registers, respectively. If either the CF1 or CF2 pin is programmed to output active energy, the CF output is disabled and held high (see the Energy-to-Frequency Conversion section). If enabled, the active reverse power indication ($\overline{\text{REVP}}$) holds its current state while in the no-load condition (see the Reverse Power section). The Current Channel A active energy no-load condition is indicated by the AP_NOLOADA bit (Bit 6) in the IRQSTATA register (Address 0x22D and Address 0x32D). The Current Channel B active energy no-load condition is indicated by the AP_NOLOADB bit (Bit 6) in the IRQSTATB register (Address 0x230 and Address 0x330).

Current Channel A and Current Channel B are independent and, therefore, a no-load condition on Current Channel A affects only the energy accumulation, CF output, and reverse power of Current Channel A, and vice versa.

The active energy no-load feature is enabled by default and can be disabled by setting Bit 0 in the DISNOLOAD register (Address 0x001) to 1.

Active Energy No-Load Interrupt

Two interrupts are associated with the active energy no-load feature: one for Current Channel A (phase) and one for Current Channel B (neutral). If enabled, these interrupts are triggered when the active energy falls below the programmed threshold.

The Current Channel A active energy no-load interrupt can be enabled by setting the AP_NOLOADA bit (Bit 6) in the IRQENA register (Address 0x22C and Address 0x32C). When this bit is set, an active energy no-load event on Current Channel A causes the $\overline{\text{IRQ}}$ pin (Pin 22) to fall to 0 (see the Primary Interrupts (Voltage Channel and Current Channel A) section).

The Current Channel B active energy no-load interrupt can be enabled by setting the AP_NOLOADB bit (Bit 6) in the IRQENB register (Address 0x22F and Address 0x32F). When this bit is set, an active energy no-load event on Current Channel B triggers the $\overline{\text{IRQ}}$ alternative output (see the Current Channel B Interrupts section).

Active Energy No-Load Status Bits

In addition to the active energy no-load interrupt, the [ADE7953](#) includes two unlatched status bits that continually monitor the no-load status of Current Channel A and Current Channel B. The ACTNLOAD_A and ACTNLOAD_B bits are located in the ACCMODE register (Address 0x201 and Address 0x301). These bits differ from the interrupt status bits in that they are unlatched and can, therefore, be used to drive an LED.

REACTIVE ENERGY NO-LOAD DETECTION

Reactive energy no-load detection can be used in conjunction with active energy no-load detection to establish a “true” no-load feature. If both the reactive and active energy fall below the no-load threshold, there is no resistive, inductive, or capacitive load. The reactive energy no-load feature can also be used to prevent creep of the reactive energy when there is a resistive load present.

If the reactive energy on either Current Channel A (phase) or Current Channel B (neutral) falls below the programmed threshold, the reactive energy on that channel ceases to accumulate in the RENERGYA and RENERGYB registers, respectively. If either the CF1 or CF2 pin is programmed to output reactive energy, the CF output is disabled and held high (see the Energy-to-Frequency Conversion section). If enabled, the reactive reverse power indication holds its current state while in the no-load condition (see the Reverse Power section). The Current Channel A reactive energy no-load condition is indicated by the VAR_NOLOADA bit (Bit 7) in the IRQSTATA register (Address 0x22D and Address 0x32D). The Current Channel B reactive energy no-load condition is indicated by the VAR_NOLOADB bit (Bit 7) in the IRQSTATB register (Address 0x230 and Address 0x330).

Current Channel A and Current Channel B are independent and, therefore, a no-load condition on Current Channel A affects only the energy accumulation, CF output, and reverse power of Current Channel A, and vice versa.

The reactive energy no-load feature is enabled by default and can be disabled by setting Bit 1 in the DISNOLOAD register (Address 0x001) to 1.

Reactive Energy No-Load Interrupt

Two interrupts are associated with the reactive energy no-load feature: one for Current Channel A (phase) and one for Current Channel B (neutral). If enabled, these interrupts are triggered when the reactive energy falls below the programmed threshold.

The Current Channel A reactive energy no-load interrupt can be enabled by setting the VAR_NOLOADA bit (Bit 7) in the IRQENA register (Address 0x22C and Address 0x32C). When this bit is set, a reactive energy no-load event on Current Channel A causes the $\overline{\text{IRQ}}$ pin (Pin 22) to fall to 0 (see the Primary Interrupts (Voltage Channel and Current Channel A) section).

The Current Channel B reactive energy no-load interrupt can be enabled by setting the VAR_NOLOADB bit (Bit 7) in the IRQENB register (Address 0x22F and Address 0x32F). When this bit is set, a reactive power no-load event on Current Channel B triggers the $\overline{\text{IRQ}}$ alternative output (see the Current Channel B Interrupts section).

Reactive Energy No-Load Status Bits

In addition to the reactive energy no-load interrupt, the [ADE7953](#) includes two unlatched status bits that continually monitor the no-load status of Current Channel A and Current Channel B. The VARNLOAD_A and VARNLOAD_B bits are located in the ACCMODE register (Address 0x201 and Address 0x301). These bits differ from the interrupt status bits in that they are unlatched and can, therefore, be used to drive an LED.

APPARENT ENERGY NO-LOAD DETECTION

Apparent energy no-load detection can be used to determine whether the total consumed energy is below the no-load threshold. If the apparent energy on either Current Channel A (phase) or Current Channel B (neutral) falls below the programmed threshold, the apparent energy on that channel ceases to accumulate in the APENERGYA and APENERGYB registers, respectively. If either the CF1 or CF2 pin is programmed to output apparent energy, the CF output is disabled and held high (see the Energy-to-Frequency Conversion section). The Current Channel A apparent energy no-load condition is indicated by the VA_NOLOADA bit (Bit 8) in the IRQSTATA register (Address 0x22D and Address 0x32D). The Current Channel B apparent energy no-load condition is indicated by the VA_NOLOADB bit (Bit 8) in the IRQSTATB register (Address 0x230 and Address 0x330).

Current Channel A and Current Channel B are independent and, therefore, a no-load condition on Current Channel A affects only the energy accumulation and CF output of Current Channel A, and vice versa.

The apparent energy no-load feature is enabled by default and can be disabled by setting Bit 2 in the DISNOLOAD register (Address 0x001) to 1.

Apparent Energy No-Load Interrupt

Two interrupts are associated with the apparent energy no-load feature: one for Current Channel A (phase) and one for Current Channel B (neutral). If enabled, these interrupts are triggered when the apparent energy falls below the programmed threshold.

The Current Channel A apparent energy no-load interrupt can be enabled by setting the VA_NOLOADA bit (Bit 8) in the IRQENA register (Address 0x22C and Address 0x32C). When this bit is set, an apparent energy no-load event on Current Channel A causes the $\overline{\text{IRQ}}$ pin (Pin 22) to fall to 0 (see the Primary Interrupts (Voltage Channel and Current Channel A) section).

The Current Channel B apparent energy no-load interrupt can be enabled by setting the VA_NOLOADB bit (Bit 8) in the IRQBENB register (Address 0x22F and Address 0x32F). When this bit is set, an apparent energy no-load event on Current Channel B triggers the $\overline{\text{IRQ}}$ alternative output (see the Current Channel B Interrupts section).

Apparent Energy No-Load Status Bits

In addition to the apparent energy no-load interrupt, the ADE7953 includes two unlatched status bits that continually monitor the no-load status of Current Channel A and Current Channel B. The VANLOAD_A and VANLOAD_B bits are located in the ACCMODE register (Address 0x201 and Address 0x301). These bits differ from the interrupt status bits in that they are unlatched and can, therefore, be used to drive an LED.

ZERO-CROSSING DETECTION

The ADE7953 includes a zero-crossing (ZX) detection feature on all three input channels. Zero-crossing detection allows measurements to be synchronized to the frequency of the incoming waveforms.

Zero-crossing detection is performed at the output of LPF1 to ensure that no harmonics or distortion affect the accuracy of the zero-crossing measurement. LPF1 is a single-pole filter with a -3 dB cutoff of 80 Hz and is clocked at 223 kHz. The phase shift of this filter therefore results in a time delay of approximately 2.2 ms (39.6°) at 50 Hz. To assure good resolution of the ZX detection, LPF1 cannot be disabled. Figure 61 shows how the zero-crossing signal is detected.

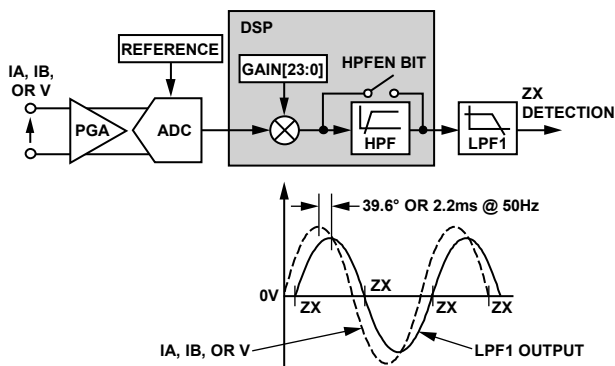

Figure 61. Zero-Crossing Detection

The error in the ZX detection is 0.08° for 50 Hz systems and 0.09° for 60 Hz systems. The zero-crossing information is available on both an output pin or via an interrupt.

ZERO-CROSSING OUTPUT PINS

By default, the voltage and current channel ZX information is configured to be output on Pin 1 (ZX) and Pin 21 (ZX_I), respectively. These dedicated output pins provide an unlatched ZX indicator (see the Alternative Output Functions section).

Voltage Channel Zero Crossing

The voltage channel zero-crossing indicator is output on Pin 1 (ZX) by default. Figure 62 shows the operation of the ZX output.

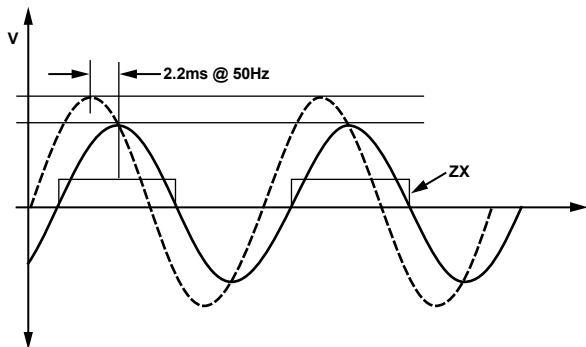

Figure 62. Voltage Channel ZX Output

As shown in Figure 62, the ZX output pin goes high on the positive-going edge of the voltage channel zero crossing and low on the negative-going edge of the zero crossing. A delay of approximately 2.2 ms should be expected on this pin due to the time delay of LPF1.

Current Channel Zero Crossing

The current channel zero-crossing indicator is output on Pin 21 (ZX_I) by default. The ZX_I pin operates in a similar way to the ZX pin (see Figure 62). The ZX_I pin goes high on the positive-going edge of the current channel zero crossing and low on the negative-going edge of the current channel zero crossing. By default, the ZX_I pin is triggered based on Current Channel A. The ZX_I pin can be configured to trigger based on Current Channel B by setting the ZX_I bit (Bit 11) of the CONFIG register (Address 0x102) to 1.

ZERO-CROSSING INTERRUPTS

Three interrupts are associated with zero-crossing detection, one for each input channel: Current Channel A, Current Channel B, and the voltage channel. The zero-crossing condition occurs when either a positive or a negative zero-crossing transition takes place. If this transition occurs on the voltage channel, the ZXV bit (Bit 15) of the IRQSTATA register (Address 0x22D and Address 0x32D) is set to 1. If this transition occurs on Current Channel A, the ZXIA bit (Bit 12) of the IRQSTATA register is set to 1. If this transition occurs on Current Channel B, the ZXIB bit (Bit 12) of the IRQSTATB register (Address 0x230 and Address 0x330) is set to 1. Figure 63 shows the operation of the voltage channel zero-crossing interrupt.

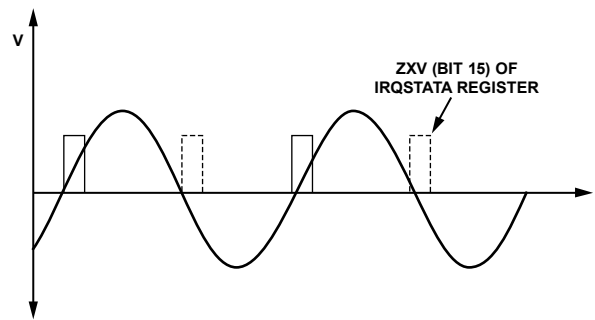

Figure 63. Zero-Crossing Interrupt

As shown by the dotted line in Figure 63, the ADE7953 can be configured to trigger a zero-crossing event on only the positive-going or the negative-going zero crossing. The ZX_EDGE bits (Bits[13:12]) of the CONFIG register (Address 0x102) set the edge that triggers the zero-crossing event. These bits default to 00 (the zero-crossing event is triggered on both the positive-going and negative-going edges). Changing the ZX_EDGE bits affects the zero-crossing event on all three channels. Note that changing the ZX_EDGE bits affects only the ZX status bits and interrupts; the function of the ZX pin (Pin 1) and the ZX_I pin (Pin 21) is not affected.

A zero-crossing event on any of the three input channels can be configured to trigger an external interrupt. All zero-crossing external interrupts are disabled by default. The voltage channel zero-crossing interrupt is enabled by setting the ZXV bit (Bit 15) in the IRQENA register (Address 0x22C and Address 0x32C). If this bit is set, a voltage channel zero-crossing event causes the $\overline{\text{IRQ}}$ pin to go low. The Current Channel A zero-crossing interrupt is enabled by setting the ZXIA bit (Bit 12) in the IRQENA register (Address 0x22C and Address 0x32C). If this bit is set, a Current Channel A zero-crossing event causes the $\overline{\text{IRQ}}$ pin to go low. The Current Channel B zero-crossing interrupt is enabled by setting the ZXIB bit (Bit 12) in the IRQENB register (Address 0x22F and Address 0x32F). If this bit is set, a Current Channel B zero-crossing event causes the $\overline{\text{IRQ}}$ pin to go low (see the ADE7953 Interrupts section).

ZERO-CROSSING TIMEOUT

The ADE7953 includes a zero-crossing timeout feature that is designed to detect when no zero crossings are obtained over a programmable time period. This feature is available on both current channels and the voltage channel and can be used to detect when the input signal has dropped out. The duration of the zero-crossing timeout is programmed in the 16-bit ZXTOUT register (Address 0x100). The same timeout duration is used for all three channels. The value in the ZXTOUT register is decremented by 1 LSB every 14 kHz (CLKIN/256). If a zero crossing is obtained, the ZXTOUT register is reloaded. If the ZXTOUT register reaches 0, a zero-crossing timeout event is issued. The ZXTOUT register has a resolution of 0.07 ms (1/14 kHz); therefore, the maximum programmable timeout period is 4.58 seconds.

As shown in Figure 64, a zero-crossing event causes one of the zero-crossing timeout bits—ZXTO, ZXTO_IA, or ZXTO_IB—to be set to 1. The ZXTO and ZXTO_IA bits are located in the IRQSTATA register (Address 0x22D and Address 0x32D) and are set when a zero-crossing timeout event occurs on the voltage channel or on Current Channel A, respectively. The ZXTO_IB bit is located in the IRQSTATB register (Address 0x230 and Address 0x330) and is set when a zero-crossing timeout event occurs on Current Channel B.

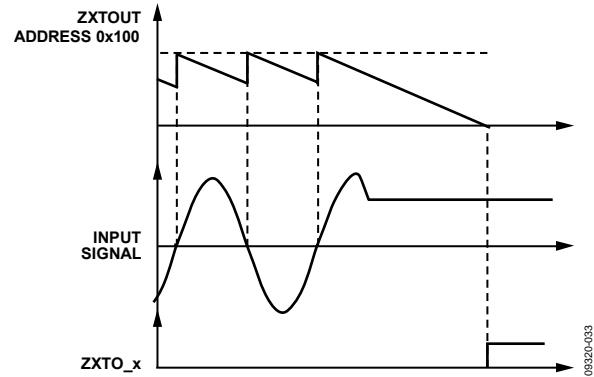

Figure 64. Zero-Crossing Timeout

Three interrupts are associated with the zero-crossing timeout feature. If enabled, a zero-crossing timeout event causes the external $\overline{\text{IRQ}}$ pin to go low. The interrupt associated with the voltage channel zero-crossing timeout can be enabled by setting the ZXTO bit (Bit 14) of the IRQENA register (Address 0x22C and Address 0x32C). The Current Channel A interrupt can be enabled by setting the ZXTO_IA bit (Bit 11) of the IRQENA register (Address 0x22C and Address 0x32C), and the Current Channel B interrupt can be enabled by setting the ZXTO_IB bit (Bit 11) of the IRQENB register (Address 0x22F and Address 0x32F). All three interrupts are disabled by default (see the ADE7953 Interrupts section).

ZERO-CROSSING THRESHOLD

To prevent spurious zero crossings when a very small input is present, an internal threshold is included on all channels of the ADE7953. This fixed threshold is set to a range of 1250:1 of the input full scale. If any input signal falls below this level, no zero-crossing signals are produced by the ADE7953 because they can be assumed to be noise. This threshold affects both the external zero-crossing pins, ZX (Pin 1) and ZX_I (Pin 21), as well as the zero-crossing interrupt function. At inputs of lower than 1250:1 of the full scale, the zero-crossing timeout signal continues to function and issues an event according to the time duration programmed in the ZXTOUT register (Address 0x100).

VOLTAGE SAG DETECTION

The ADE7953 includes a sag detection feature that warns the user when the absolute value of the line voltage falls below the programmable threshold for a programmable number of line cycles. This feature can provide an early warning signal that the line voltage is dropping out. The voltage sag feature is controlled by two registers: SAGCYC (Address 0x000) and SAGLVL (Address 0x200 and Address 0x300). These registers control the sag period and the sag voltage threshold, respectively.

Sag detection is disabled by default and can be enabled by writing a nonzero value to both the SAGCYC and SAGLVL registers. If either register is set to 0, the sag feature is disabled. If a voltage sag condition occurs, the sag bit (Bit 19) in the IRQSTATA register (Address 0x22D and Address 0x32D) and in the RSTIRQSTATA register (Address 0x22E and Address 0x32E) is set to 1.

SETTING THE SAGCYC REGISTER

The 8-bit, unsigned SAGCYC register contains the programmable sag period. The sag period is the number of half line cycles below which the voltage channel must remain before a sag condition occurs. Each LSB of the SAGCYC register corresponds to one half line cycle period. The SAGCYC register holds a maximum value of 255.

At 50 Hz, the maximum sag cycle time is 2.55 seconds.

$$\left(\frac{1}{50} \div 2\right) \times 255 = 2.55 \text{ sec}$$

At 60 Hz, the maximum sag cycle time is 2.125 seconds.

$$\left(\frac{1}{60} \div 2\right) \times 255 = 2.125 \text{ sec}$$

If the SAGCYC value is modified after the feature is enabled, the new SAGCYC period is effective immediately. Therefore, it is possible for a sag event to be caused by a combination of sag cycle periods. To prevent any overlap, the SAGLVL register should be reset to 0 to effectively disable the feature before the new cycle value is written to the SAGCYC register.

SETTING THE SAGLVL REGISTER

The 24-bit/32-bit SAGLVL register contains the amplitude that the voltage channel must fall below before a sag event occurs. Each LSB of this register maps exactly to the voltage channel peak register; therefore, the amplitude can be set based on the peak reading of the voltage channel. To set the SAGLVL register, nominal voltage should be applied and a reading taken from the RSTVPEAK register (Address 0x227 and Address 0x327) to reset the peak level reading. After a wait period of a few line cycles, the VPEAK register (Address 0x226 and Address 0x326) should be read to determine the voltage input. This reading should then be scaled to the amplitude required for sag detection.

For example, if a sag threshold of 80% of the nominal voltage is required, the peak reading should be taken and a value of 80% of this reading should be written to the SAGLVL register. This method ensures that an accurate SAGLVL value is obtained for the particular design.

VOLTAGE SAG INTERRUPT

The ADE7953 includes an interrupt that is associated with the voltage sag detection feature. If this interrupt is enabled, a voltage sag event causes the external $\overline{\text{IRQ}}$ pin to go low. This interrupt is disabled by default and can be enabled by setting the sag bit (Bit 19) in the IRQENA register (Address 0x22C and Address 0x32C). See the ADE7953 Interrupts section.

PEAK DETECTION

The ADE7953 includes a peak detection feature on both Current Channel A (phase) and Current Channel B (neutral) and on the voltage channel. This feature continuously records the maximum value of the voltage and current waveforms.

Peak detection can be used with overvoltage and overcurrent detection to provide a complete swell detection function (see the Overcurrent and Overvoltage Detection section).

Peak detection is an instantaneous measurement taken from the absolute value of the current and voltage ADC output waveforms and stored in three 24-bit/32-bit registers. The three registers that record the peak values on Current Channel A, Current Channel B, and the voltage channel, respectively, are IAPEAK (Address 0x228 and Address 0x328), IBPEAK (Address 0x22A and Address 0x32A), and VPEAK (Address 0x226 and Address 0x326).

These three registers are updated every time that the absolute value of the waveform exceeds the current value stored in the IAPEAK, IBPEAK, and VPEAK registers. No time period is associated with this measurement.

Three additional registers contain the same peak information, but cause the corresponding peak measurements to be reset after they are read. The three read-with-reset peak registers are RSTIAPEAK (Address 0x229 and Address 0x329), RSTIBPEAK (Address 0x22B and Address 0x32B), and RSTVPEAK (Address 0x227 and Address 0x327). Reading these registers clears the contents of the corresponding xPEAK register.

INDICATION OF POWER DIRECTION

The ADE7953 includes sign indication on the active and reactive energy measurements. Sign indication allows positive and negative energy to be identified and billed separately if required. It also helps detect a miswiring condition. This feature is available on both Current Channel A and Current Channel B. Power direction information is available on both a dedicated output pin ($\overline{\text{REVP}}$) and via a set of internal registers and interrupts (see the Reverse Power section and the Sign Indication section).

REVERSE POWER

The $\overline{\text{REVP}}$ pin (Pin 20) on the ADE7953 provides a reverse power indicator. This pin can be configured to provide polarity information about the active or reactive power on Current Channel A or Current Channel B. The $\overline{\text{REVP}}$ output is high by default and goes low if the angle between the voltage and current input is greater than 90° . $\overline{\text{REVP}}$ is unlatched and, therefore, returns high when the reverse power condition is no longer true. Changes to the $\overline{\text{REVP}}$ output pin occur synchronously to the falling edge of the CF1 pin by default (see Figure 65).

The measurement and channel indicated by the $\overline{\text{REVP}}$ pin are selected by the configuration of the CF output. By default, the $\overline{\text{REVP}}$ pin is configured to output synchronous to CF1 and represents the measurement selected on CF1 using the CF1SEL bits in the CFMODE register (Address 0x107). By default, this measurement is the active power on Current Channel A. If the CF1SEL bits are set to 0x0001, the $\overline{\text{REVP}}$ pin indicates the polarity of the reactive power on Current Channel A. The $\overline{\text{REVP}}$ indicator can be configured to output based on CF2 by setting the REVP_CF bit in the CONFIG register (Address 0x102). In this configuration, the CF2SEL bits in the CFMODE register determine the measurement represented on the $\overline{\text{REVP}}$ output. If the selected CF pin is configured to output another measurement, such as apparent power or IRMS, the $\overline{\text{REVP}}$ output is disabled.

To improve the visibility of a reverse polarity condition if an LED light is used, a 1 Hz pulse mode is available on the $\overline{\text{REVP}}$ pin. In this mode, the $\overline{\text{REVP}}$ output pin is low by default and outputs a 1 Hz pulse if the reverse polarity condition is true.

This pulse has a 50% duty cycle. Similar to normal mode, this mode is also unlatched, and the $\overline{\text{REVP}}$ output returns high when the reverse polarity is no longer true. To enable the $\overline{\text{REVP}}$ pulse mode, the REVP_PULSE bit in the CONFIG register (Address 0x102) should be set to 1.

The $\overline{\text{REVP}}$ output pin is disabled in the corresponding no-load condition. For example, if the reverse polarity information for Current Channel A active power is present on the $\overline{\text{REVP}}$ pin and the active energy on Current Channel A is in the no-load condition, the $\overline{\text{REVP}}$ output is disabled and held in its current state.

SIGN INDICATION

The ADE7953 includes four sign indication bits that indicate the polarity of the active power on Current Channel A (APSIGN_A), the active power on Current Channel B (APSIGN_B), the reactive power on Current Channel A (VARSIGN_A), and the reactive power on Current Channel B (VARSIGN_B). These bits are located in the ACCMODE register (Address 0x201 and Address 0x301). All four bits are unlatched and read only. A low reading (0) on any of these bits indicates that the corresponding power reading is positive; a high reading (1) indicates that the corresponding power reading is negative. These bits are enabled by default and are disabled in the corresponding no-load condition.

In addition to the sign indication bits, the ADE7953 also includes four sign indication interrupts. If enabled, these interrupts cause the IRQ pin to go low when the polarity of the power changes. The interrupts are triggered on both positive-to-negative and negative-to-positive polarity changes. These interrupts are disabled by default and can be enabled by setting the APSIGN_A and VARSIGN_A bits in the IRQENA register (Address 0x22C and Address 0x32C), and the APSIGN_B and VARSIGN_B bits in the IRQENB register (Address 0x22F and Address 0x32F). See the ADE7953 Interrupts section.

Note that in absolute or positive-only accumulation mode, these bits are fixed at 0. See the Active Energy Accumulation Modes section and the Reactive Energy Accumulation Modes section.

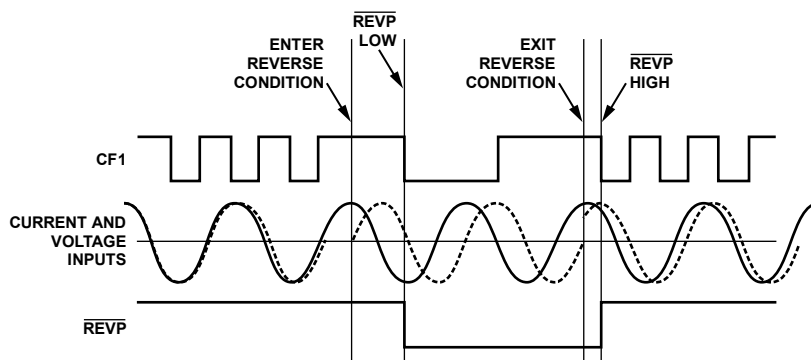

Figure 65. $\overline{\text{REVP}}$ Output

OVERCURRENT AND OVERVOLTAGE DETECTION

The ADE7953 provides an overcurrent and overvoltage feature that detects whether the absolute value of the current or voltage waveform exceeds a programmable threshold. This feature uses the instantaneous voltage and current signals. The two registers associated with this feature, OVLVL (Address 0x224 and Address 0x324) and OILVL (Address 0x225 and Address 0x325), are used to set the voltage and current channel thresholds, respectively. The OILVL threshold register determines the threshold for both the Current Channel A and Current Channel B overcurrent features. The same threshold must therefore be used for both Current Channel A and Current Channel B. The default value of the OVLVL and OILVL registers is 0xFFFFF, which effectively disables the feature. Figure 66 shows the operation of the overvoltage detection feature.

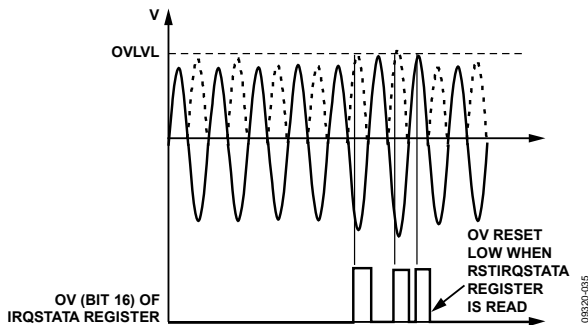

Figure 66. Overvoltage Detection

As shown in Figure 66, if the ADE7953 detects an overvoltage condition, the OV bit (Bit 16) of the IRQSTATA register (Address 0x22D and Address 0x32D) is set to 1. This bit can be cleared by reading the RSTIRQSTATA register (Address 0x22E and Address 0x32E). The overcurrent detection feature works in a similar manner (see Figure 67).

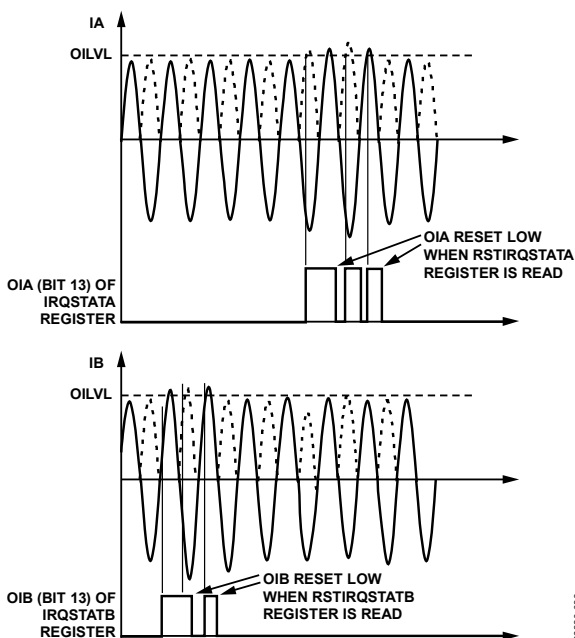

Figure 67. Overcurrent Detection

As shown in Figure 67, if an overcurrent condition is detected on Current Channel A, the OIA bit (Bit 13) of the IRQSTATA register is set to 1. This bit can be cleared by reading from the RSTIRQSTATA register. If an overcurrent condition is detected on Current Channel B, the OIB bit (Bit 13) of the IRQSTATB register (Address 0x230 and Address 0x330) is set to 1. This bit can be cleared by reading from the RSTIRQSTATB register (Address 0x231 and Address 0x331).

SETTING THE OVLVL AND OILVL REGISTERS

The 24-bit/32-bit unsigned OVLVL and OILVL registers map directly to the VPEAK (Address 0x226 and Address 0x326) and IAPEAK (Address 0x228 and Address 0x328) registers, respectively (see the Peak Detection section). Note that after gain calibration, Current Channel A and Current Channel B are matched and, therefore, the IAPEAK and IBPEAK registers are matched with common inputs. The settings of the OVLVL and OILVL registers should be based on the VPEAK and IAPEAK readings with full-scale inputs.

To set the OVLVL register, the maximum voltage input should be applied and a reading taken from the RSTVPEAK register (Address 0x227 and Address 0x327). This resets the voltage peak reading. After a wait period of a few line cycles, the VPEAK register (Address 0x226 and Address 0x326) should be read to determine the voltage peak. This reading should then be scaled to the amplitude required for overvoltage detection. For example, if an overvoltage threshold of 120% of the maximum voltage is required, the peak reading should be multiplied by 1.2 and the resulting value written to the OVLVL register. This method ensures that an accurate threshold is set for each individual design.

OVERVOLTAGE AND OVERCURRENT INTERRUPTS

Three interrupts are associated with the overvoltage and overcurrent features. The first interrupt is associated with the overvoltage feature; it is enabled by setting the OV bit (Bit 16) of the IRQENA register (Address 0x22C and Address 0x32C). When this bit is set, an overvoltage condition causes the external $\overline{\text{IRQ}}$ pin to be pulled low.

A second interrupt is associated with the overcurrent detection feature on Current Channel A. This interrupt is enabled by setting the OIA bit (Bit 13) of the IRQENA register. When this bit is set, an overcurrent condition on Current Channel A causes the external $\overline{\text{IRQ}}$ pin to be pulled low.

The third interrupt is associated with the overcurrent detection feature on Current Channel B. This interrupt is enabled by setting the OIB bit (Bit 13) of the IRQENB register (Address 0x22F and Address 0x32F). When this bit is set, an overcurrent condition on Current Channel B causes the $\overline{\text{IRQ}}$ alternative output to be triggered, if the alternative output is enabled (see the Current Channel B Interrupts section).

ALTERNATIVE OUTPUT FUNCTIONS

The ADE7953 includes three output pins that are configured by default to output power quality information.

- Pin 1 (ZX) provides a voltage channel zero-crossing signal, as described in the Voltage Channel Zero Crossing section.
- Pin 21 (ZX_I) provides a current channel zero-crossing signal, as described in the Current Channel Zero Crossing section.
- Pin 20 (REVP) provides polarity information, as described in the Reverse Power section.

To provide flexibility and to accommodate a variety of design requirements, the ADE7953 can be configured to output a variety of alternative power quality signals on any of these three outputs. Alternative functions are configured using the ALT_OUTPUT register (Address 0x110).

Table 8 summarizes the functions that can be output on Pin 1, Pin 21, and Pin 20. Note that the default functions of ZX, ZX_I, and REVP can be configured to output on any one of Pin 1, Pin 21, or Pin 20.

As described in Table 8, the description of each function can be found in the corresponding section of this data sheet. If an alternative output function is enabled on Pin 1, Pin 21, or Pin 20, the function can be configured and will be performed as described in the corresponding section. The alternative function will, however, appear as an unlatched output on Pin 1, Pin 21, or Pin 20.

To enable an alternative function, the ZX_ALT, ZXI_ALT, and REVP_ALT bits in the ALT_OUTPUT register must be set. The interrupt enable associated with the alternative output does not need to be enabled in order for it to be present on Pin 1, Pin 21, or Pin 20. Enabling an alternative output does not affect the primary function of the feature.

Table 8. Alternative Outputs

| Function | See This Section |
|---|--|
| Zero-crossing detection (voltage channel) | Voltage Channel Zero Crossing |
| Zero-crossing detection (current channels) | Current Channel Zero Crossing |
| Reverse power indication | Reverse Power |
| Voltage sag detection | Voltage Sag Detection |
| Active energy no-load detection (Current Channel A) | Active Energy No-Load Detection |
| Active energy no-load detection (Current Channel B) | Active Energy No-Load Detection |
| Reactive energy no-load detection (Current Channel A) | Reactive Energy No-Load Detection |
| Reactive energy no-load detection (Current Channel B) | Reactive Energy No-Load Detection |
| Waveform sampling, data ready | Instantaneous Powers and Waveform Sampling |
| Interrupt output (Current Channel B) | Current Channel B Interrupts |

ADE7953 INTERRUPTS

The ADE7953 interrupts are separated into two groups. The first group of interrupts is associated with the voltage channel and Current Channel A. The second group of interrupts is associated with Current Channel B. See Table 22 and Table 24 for a list of the interrupts.

All interrupts are disabled by default with the exception of the RESET interrupt that is located within the group of primary interrupts. This interrupt is enabled by default and signals the end of a software or hardware reset. On power-up, this interrupt is triggered to signal that the ADE7953 is ready to receive communication from the microcontroller. This interrupt should be serviced as described in the Primary Interrupts (Voltage Channel and Current Channel A) section prior to configuring the ADE7953.

PRIMARY INTERRUPTS (VOLTAGE CHANNEL AND CURRENT CHANNEL A)

The primary interrupts are events that occur on the voltage channel and Current Channel A. These interrupts are handled by a group of three registers: the enable register, IRQENA (Address 0x22C and Address 0x32C), the status register, IRQSTATA (Address 0x22D and Address 0x32D), and the reset status register, RSTIRQSTATA (Address 0x22E and Address 0x32E). The bits in these registers are described in Table 22 and Table 23.

When an interrupt event occurs, the corresponding bit in the IRQSTATA register is set to 1. If the enable bit for this interrupt, located in the IRQENA register, is set to 1, the external $\overline{\text{IRQ}}$ pin is pulled to Logic 0. The status bits located in the IRQSTATA register are set when an interrupt event occurs, regardless of whether the external interrupt is enabled.

All interrupts are latched and require servicing to clear. To service the interrupt and return the $\overline{\text{IRQ}}$ pin to Logic 1, the status bits must be cleared using the RSTIRQSTATA register (Address 0x22E and Address 0x32E). The RSTIRQSTATA register contains the same interrupt status bits as the IRQSTATA

register, but when the RSTIRQSTATA register is accessed, a read-with-reset command is executed, clearing the status bits. After completion of a read from this register, all status bits are cleared to 0 and the $\overline{\text{IRQ}}$ pin returns to Logic 1.

CURRENT CHANNEL B INTERRUPTS

The Current Channel B interrupts are events that occur on Current Channel B. Like the primary group of interrupts, Current Channel B interrupts are handled by a group of three registers: the enable register, IRQENB (Address 0x22F and Address 0x32F), the status register, IRQSTATB (Address 0x230 and Address 0x330), and the reset status register, RSTIRQSTATB (Address 0x231 and Address 0x331). The bits in these registers are described in Table 24 and Table 25.

When an interrupt event occurs, the corresponding bit in the IRQSTATB register is set to 1. The Current Channel B interrupts do not have a dedicated output pin. This function can be configured as an alternative output on Pin 1 (ZX), Pin 21 (ZX_I), or Pin 20 (REVP) (see the Alternative Output Functions section). If an output is enabled for interrupt events on Current Channel B and the interrupt enable bit, located in the IRQENB register, is set to 1, Pin 1, Pin 21, or Pin 20 is pulled low if an interrupt event occurs on Current Channel B. The status bits located in the IRQSTATB register are set when an interrupt event occurs, regardless of whether an external interrupt output is enabled.

All interrupts are latched and require servicing to clear. To service the interrupt, the status bits must be cleared using the RSTIRQSTATB register (Address 0x231 and Address 0x331). The RSTIRQSTATB register contains the same interrupt status bits as the IRQSTATB register, but when the RSTIRQSTATB register is accessed, a read-with-reset command is executed, clearing the status bits. After completion of a read from this register, all status bits are cleared to 0 and the appropriate output pin (if enabled) returns to Logic 1.

COMMUNICATING WITH THE ADE7953

All [ADE7953](#) features can be accessed via a group of on-chip registers. For a detailed list of all the registers, see the ADE7953 Registers section. Three different communication interfaces can be used to access the on-chip registers.

- 4-pin SPI interface
- 2-pin bidirectional I²C interface
- 2-pin UART interface

All three communication options use the same group of pins and, therefore, only one method of communication should be used in each design.

COMMUNICATION AUTODETECTION

The [ADE7953](#) contains a detection system that automatically detects which of the three communication interfaces is being used. This feature allows communication to be quickly established with minimal initialization. Autodetection works by monitoring the status of the four communication pins and automatically selecting the communication interface that matches the configuration (see Table 9).

- The CS pin (Pin 28) is used to determine whether the communication method is SPI. If this pin is held low, the communication interface is set to SPI.
- The SCLK pin (Pin 25) is used to determine whether the communication method is I²C or UART. If this pin is held high, the communication interface is set to I²C; if it is held low, the communication interface is set to UART.

Therefore, although Pin 25 (SCLK) and Pin 28 (CS) are not required if communicating via I²C or UART, these pins should be configured in hardware as shown in Table 9 to ensure the functionality of the autodetection system.

LOCKING THE COMMUNICATION INTERFACE

After the selected communication interface is established, the interface should be locked to prevent the communication method from inadvertently changing. The [ADE7953](#) can be configured to lock automatically after the first successful communication.

The automatic lock feature is disabled by default and is enabled by clearing the COMM_LOCK bit (Bit 15) in the CONFIG register (Address 0x102). To successfully establish and lock the communication interface, a write should be issued shortly after power-up to the CONFIG register, clearing the COMM_LOCK bit and thus locking the communication interface. When the communication interface is locked to a specific method (that is, SPI, I²C, or UART), the communication method cannot be changed without resetting the [ADE7953](#).

Note that if using the SPI communication interface to lock the communication mode, the CS pin must be held low for a minimum of 1.2 μ s after the last SCLK. This delay is required only when writing to the COMM_LOCK bit (see the SPI Interface Timing section).

Table 9. Communication Autodetection

| Communication Interface | Pin 28 (CS) | Pin 25 (SCLK) | Pin 27 (MOSI/SCL/Rx) | Pin 26 (MISO/SDA/Tx) |
|-------------------------|-------------|---------------|----------------------|----------------------|
| SPI | 0 | Don't care | MOSI | MISO |
| I ² C | 1 | 1 | SCL | SDA |
| UART | 1 | 0 | Rx | Tx |

SPI INTERFACE

The serial peripheral interface (SPI) uses all four communication pins: CS, SCLK, MOSI, and MISO. The SPI communication operates in slave mode and, therefore, a clock must be provided on the SCLK pin (MOSI is an input, and MISO is an output). This clock synchronizes all communications and can operate up to a maximum speed of 5 MHz. See the SPI Interface Timing section for more information about the communication timing requirements.

The MOSI pin is an input to the ADE7953; data is shifted in on the falling edge of SCLK to be sampled by the ADE7953 on the rising edge. The MISO pin is an output from the ADE7953; data is shifted out on the falling edge of SCLK and should be sampled by the external microcontroller on the rising edge.

The SPI communication packet consists of two initial bytes that contain the address of the register that is to be read from or written to. This address should be transmitted MSB first. The third byte of the communication determines whether a read or a write is being issued.

The most significant bit of this byte should be set to 1 for a read operation and to 0 for a write operation. When the third byte transmission is complete, the register data is either sent from the ADE7953 on the MISO pin (in the case of a read) or is written to the ADE7953 MOSI pin by the external microcontroller (in the case of a write). All data is sent or received MSB first. The length of the data transfer depends on the width of the register being accessed. Registers can be 8, 16, 24, or 32 bits long.

Figure 68 and Figure 69 show the data transfer sequence for an SPI read and an SPI write, respectively. As shown in these figures, the CS (chip select) input must be driven low to initialize the communication and driven high at the end of the communication. Bringing the CS input high before the completion of a data transfer ends the communication. In this way, the CS input performs a reset function on the SPI communication. The CS input allows communication with multiple devices on the same microcontroller SPI port.

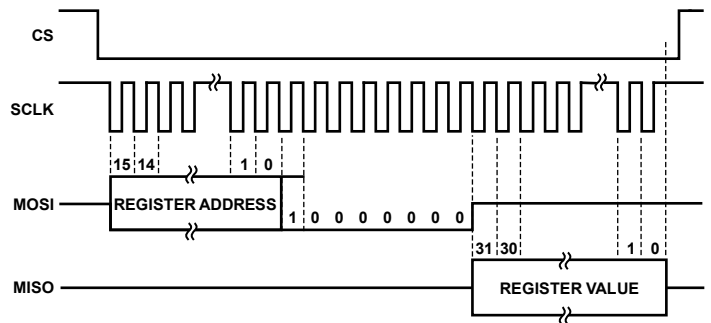

Figure 68. SPI Read

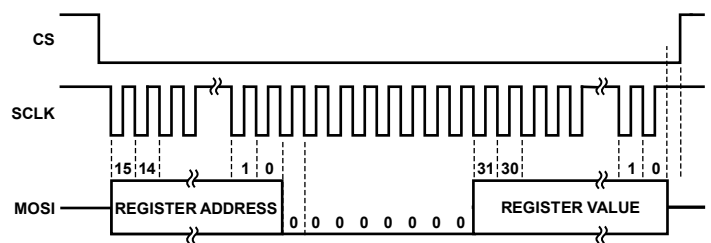

Figure 69. SPI Write

I²C INTERFACE

The ADE7953 supports a fully licensed I²C interface. The I²C interface operates as a slave and uses two shared pins: SDA and SCL. The SDA pin is a bidirectional input/output pin, and the SCL pin is the serial clock. Both pins are shared with the SPI and UART interfaces. The I²C interface operates at a maximum serial clock frequency of 400 kHz.

The two pins used for data transfer—SDA and SCL—are configured in a wire-AND format that allows arbitration in a multimaster system.

Communication via the I²C interface is initiated by the master device generating a start condition. This consists of the master transmitting a single byte containing the address of the slave device and the nature of the operation (read or write).

The address of the ADE7953 is 0111000X. Bit 7 in the address byte indicates whether a read or a write is required: 0 indicates a write, and 1 indicates a read. The communication continues as described in the following sections until the master issues a stop condition and the bus returns to the idle condition.

I²C Write Operations

A write operation on the ADE7953 is initiated when the master issues a start condition, which consists of the slave address and the read/write bit. The start condition is followed by the 16-bit address of the target register. After each byte is received, the ADE7953 issues an acknowledge (ACK) to the master.

As soon as the 16-bit address communication is complete, the master sends the register data, MSB first. The length of this data can be 8, 16, 24, or 32 bits long. After each byte of register data is received, the ADE7953 slave issues an acknowledge (ACK). When transmission of the final byte is complete, the master issues a stop condition, and the bus returns to the idle condition. The I²C write operation is shown in Figure 70.

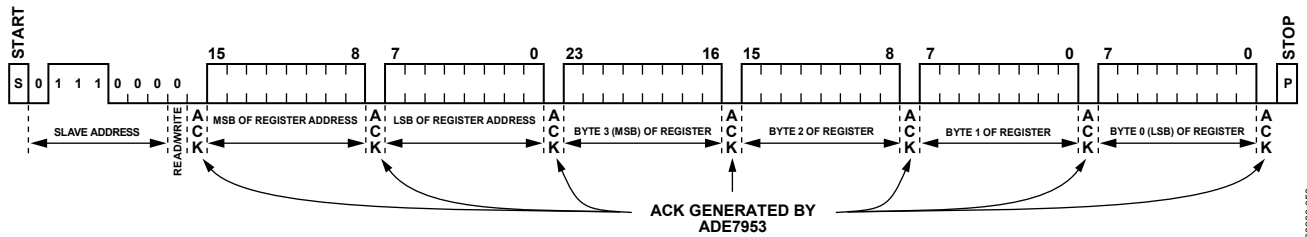

Figure 70. I²C Write

09320-059

I²C Read Operations

The I²C read operation is performed in two stages. The first stage sets the pointer to the address of the register to be accessed. The second stage reads the contents of the register.

As shown in Figure 71, the first stage is initiated when the master issues a start condition, which consists of the slave address and the read/write bit. Because this first step sets up the pointer to the address, the LSB of the start byte should be set to 0 (write). The start condition is followed by the 16-bit address of the target register. After each byte is received, the ADE7953 issues an acknowledge (ACK) to the master.

The second stage of the read operation begins with the master generating a new start condition. This start condition consists of the same slave address but with the LSB set to 1 to signify that a read is being issued. After this byte is received, the ADE7953 issues an acknowledge (ACK). The ADE7953 then sends the register contents to the master, which acknowledges the reception of each byte. All bytes are sent MSB first. The register contents can be 8, 16, 24, or 32 bits long. After the final byte of register data is received, the master issues a stop condition in place of the acknowledge to indicate the completion of the communication. The I²C read operation is shown in Figure 71.

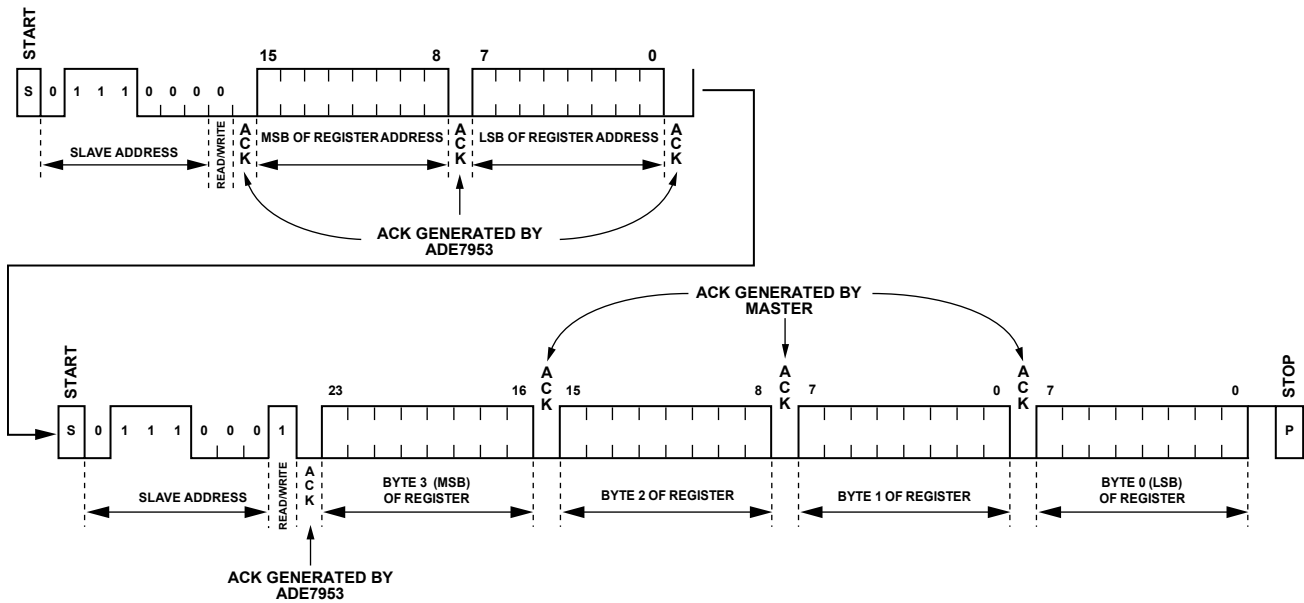

Figure 71. I²C Read

06320-060

UART INTERFACE

The ADE7953 provides a simple universal asynchronous receiver/transmitter (UART) interface that allows all the functions of the ADE7953 to be accessed using only two single-direction pins. The UART interface allows an isolated communication interface to be achieved using only two low cost opto-isolators. The UART interface operates at a fixed baud rate of 4800 bps and is therefore suitable for low speed designs.

The UART interface on the ADE7953 is accessed via the Tx pin (Pin 26), which transmits data from the ADE7953, and the Rx pin (Pin 27), which receives data from the microcontroller. A simple master/slave topology is implemented on the UART interface with the ADE7953 acting as the slave. All communication is initiated by the sending of a valid frame by the master (the microcontroller) to the slave (the ADE7953). The format of the frame is shown in Figure 72.

As shown in Figure 72, each frame consists of 10 bits. Each bit is sent at a bit rate of 4800 bps, resulting in a frame time of 2.08 ms $((1/4800) \times 10)$. A wait period of 6 ms should be added from when the UART communication mode is established using the CS and SCLK pins to when the first frame is sent. A minimum wait of 0.2 ms should be included between frames. All frame data is sent LSB first.

Communication via the UART interface is initiated by the master sending a packet of three frames (see Table 10).

Table 10. Frames in the UART Packet

| Frame | Function |
|-------|-------------|
| F1 | Read/write |
| F2 | Address MSB |
| F3 | Address LSB |

F1 determines whether the communication is a read or a write operation, and the following two frames (F2 and F3) select the register that is to be accessed. Each frame consists of eight data bits, as shown in Figure 72. A read is issued by writing the value 0x35 to F1, and a write is issued by writing the value 0xCA to F1. Any other value is interpreted as invalid and results in an unsuccessful communication with the ADE7953. The address bytes are sent MSB first; therefore, F2 contains the most significant portion of the address, and F3 contains the least significant portion of the address. The bits within each address frame are sent LSB first.

The ADE7953 UART interface uses two timeouts, t_1 and t_2 , to synchronize the communication and to prevent the communication from halting. The first timeout, t_1 , is the frame-to-frame delay and is fixed at 4 ms max. The second timeout, t_2 , is the packet-to-packet delay and is fixed at 6 ms min. These two timeouts act as a reset for the UART function. More information about how the timeouts are implemented is provided in the UART Read section and the UART Write section.

Verification of a successful UART communication can be achieved by implementing a write/read/verify sequence in the microcontroller. Successful communications are also recorded in the LAST_ADD, LAST_RWDATA, and LAST_OP registers, as described in the Communication Verification section.

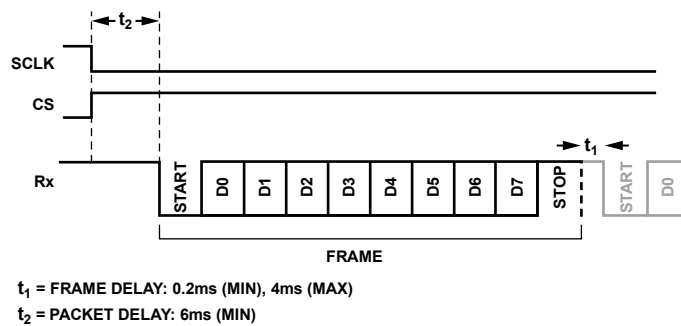

Figure 72. UART Frame

09320-141

UART Read

A read from the ADE7953 via the UART interface is initiated by the master sending a packet of three frames. If the first frame has the value 0x35, a read is being issued. The second and third frames contain the address of the register being accessed. When the ADE7953 receives a legal packet, it decodes the command (see Figure 73).

The frame time is 2.08 ms. A frame-to-frame delay (t_1) of 4 ms max provides a 50% buffer on the frame time without needlessly slowing the communication. When the read packet is decoded, the ADE7953 sends the data from the selected register out on the Tx pin (see F4 and F5 in Figure 73). This occurs approximately 0.1 ms after the complete frame is received. This data can be 1, 2, 3, or 4 bytes long, depending on the size of the register that is being accessed. The register data is sent LSB first. After the last frame of register data is sent from the ADE7953, a packet-to-packet delay (t_2) of 6 ms min is required before any incoming data on the Rx pin is accepted. This packet-to-packet timeout ensures that no overlap is possible.

UART Write

A write to the ADE7953 via the UART interface is initiated by the master sending a packet of three frames. If the first frame has the value 0xCA, a write is being issued. The second and third frames contain the address of the register being accessed. The next two frames contain the data to be written. When the ADE7953 receives a legal packet, it decodes the command as follows:

- If the number of frames obtained after the initial packet is the same as the size of the register specified by F2 and F3, the packet is legal and the corresponding register is written.
- If the number of frames does not equal the size of the specified register, the command is illegal and no further action is taken.

After the last frame of data is received on the Rx pin, a wait period of t_2 is required before any incoming data on the Rx pin is treated as a new packet. This operation is shown in Figure 74.

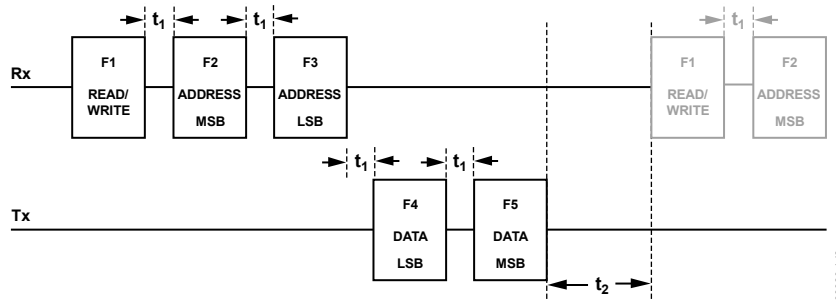

Figure 73. UART Read

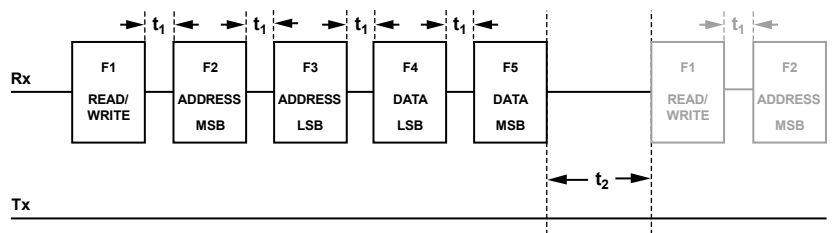

Figure 74. UART Write

COMMUNICATION VERIFICATION AND SECURITY

The [ADE7953](#) includes three security measures to increase communication robustness and to help prevent inadvertent modifications to its internal registers. The write protection, communication verification, and checksum features can be used together to help increase the robustness and noise immunity of the meter design.

WRITE PROTECTION

The [ADE7953](#) provides a simple method for protecting the internal registers from unexpected write operations. This feature helps to prevent noise or EMC conditions from changing the required meter configuration. The write protection feature is disabled by default to allow the meter to be configured and can be enabled by writing to the 8-bit `WRITE_PROTECT` register (Address 0x040). Only the three LSBs of this register are used. Bit 0 controls the protection on the 8-bit registers; Bit 1 controls the protection on the 16-bit registers; Bit 2 controls the protection on the 24-bit/32-bit registers. All bits are set to 0 by default to disable the protection. Setting any of these bits to 1 enables write protection on the corresponding group of registers. When write protection is enabled, any attempted write operation using the SPI, I²C, or UART interface is ignored. The one exception to this is the `WRITE_PROTECT` register that can still be modified to disable the write protection feature. Resetting the `WRITE_PROTECT` bits to 0 reinstates full access to the register banks.

COMMUNICATION VERIFICATION

The [ADE7953](#) includes a set of three registers that allow any communication via SPI, I²C, or UART to be verified. The `LAST_OP` (Address 0x0FD), `LAST_ADD` (Address 0x1FE), and `LAST_RWDATA` registers record the type, address, and data of the last successful communication, respectively. The `LAST_RWDATA` register has four separate addresses, depending on the length of the successful communication (see Table 11). Multiple address locations are included to prevent unnecessarily long communications.

Table 11. Addresses of the `LAST_RWDATA` Registers

| Register Address | Length of Read/Write |
|------------------|----------------------|
| Address 0x0FF | 8 bits |
| Address 0x1FF | 16 bits |
| Address 0x2FF | 24 bits |
| Address 0x3FF | 32 bits |

After each successful communication with the [ADE7953](#), the address of the last register that was accessed is stored in the 16-bit `LAST_ADD` register (Address 0x1FE). This read-only register stores the value until the next successful read or write is complete.

The `LAST_OP` register (Address 0x0FD) stores the type of the communication, that is, it indicates whether a read or a write was performed. If the last operation was a write, the `LAST_OP` register stores the value 0xCA. If the last operation was a read, the `LAST_OP` register stores the value 0x35.

The `LAST_RWDATA` register stores the data that was written to or read from the register. Unsuccessful read and write operations are not reflected in these registers.

CHECKSUM REGISTER

The ADE7953 includes a 32-bit checksum register, CRC (Address 0x37F), which warns the user if any of the important configuration, control, or calibration registers are modified. The checksum register helps to ensure that the meter configuration is not modified from its desired state during normal operation.

Table 12 lists the registers included in the checksum. An additional eight internal reserved registers are also included in the checksum. The ADE7953 computes the cyclic redundancy check (CRC) based on the IEEE 802.3 standard. The contents of the registers are introduced one by one into a linear feedback shift register (LFSR) based generator, starting with the least significant bit. The 32-bit result is written to the CRC register.

Figure 75 shows how the LFSR works. The registers shown in Table 12 and the eight 8-bit reserved internal registers form the bits [a₁₀₂₃, a₁₀₂₂, ..., a₀] used by LFSR. Bit a₀ is the least significant bit of the first register to enter LFSR; Bit a₁₀₂₃ is the most significant bit of the last register to enter LFSR.

The formulas that govern LFSR are as follows:

b_i(0) = 1, i = 0, 1, 2, ..., 31, the initial state of the bits that form the CRC. Bit b₀ is the least significant bit, and Bit b₃₁ is the most significant.

b_i(0) = 1, i = 0, 1, 2, ..., 31, the initial state of the bits that form the CRC. Bit b₀ is the least significant bit, and Bit b₃₁ is the most significant.

g_i, i = 0, 1, 2, ..., 31 are the coefficients of the generating polynomial defined by the IEEE802.3 standard as follows:

$$G(x) = x^{32} + x^{26} + x^{23} + x^{22} + x^{16} + x^{12} + x^{11} + x^{10} + x^8 + x^7 + x^5 + x^4 + x^2 + x + 1.$$

$$g_0 = g_1 = g_2 = g_4 = g_5 = g_7 = 1$$

$$g_8 = g_{10} = g_{11} = g_{12} = g_{16} = g_{22} = g_{26} = g_{31} = 1 \tag{50}$$

All of the other g_i coefficients are equal to 0.

$$FB(j) = a_{j-1} \text{ XOR } b_{31}(j-1) \tag{51}$$

$$b_0(j) = FB(j) \text{ AND } g_0 \tag{52}$$

$$b_i(j) = FB(j) \text{ AND } g_i \text{ XOR } b_{i-1}(j-1), i = 1, 2, 3, \dots, 31 \tag{53}$$

Equation 51, Equation 52, and Equation 53 must be repeated for j = 1, 2, ..., 1024. The value written into the Checksum register contains the Bit b_i(1024), i = 0, 1, ..., 31.

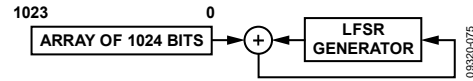

Figure 75. Checksum Register Calculation

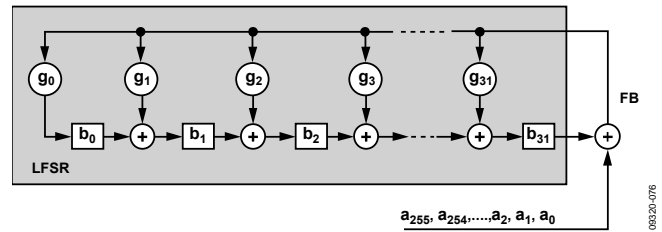

Figure 76. LFSR Generator Used in Checksum Register Calculation

The CRC is disabled by default and can be enabled by setting the CRC_ENABLE bit (Bit 8) of the CONFIG register (Address 0x102). When this bit is set, the CRC is computed at a rate of 6.99 kHz. Because the CRC is disabled by default, the default value is 0xFFFFFFFF. Once enabled, with all registers at their default value, the CRC is 0x48739163. The checksum can be used to ensure that the registers included in the checksum are not inadvertently changed by periodically reading the value in the CRC register (Address 0x37F) after the meter is configured.

If two consecutive readings differ, it can be assumed that one of the registers has changed value and, therefore, the configuration of the ADE7953 has changed. Note that since the CRC updates at a rate of 6.99 kHz, consecutive reads should be at least 143 μs (1/6.99 kHz) apart. The recommended response is to issue a hardware/software reset, which resets all ADE7953 registers, including reserved registers, to their default values. The ADE7953 should then be reconfigured with the design-specific settings.

An interrupt associated with the checksum feature can provide an external warning signal on the IRQ pin if the CRC register value changes after initial configuration. This interrupt is disabled by default and can be enabled by setting the CRC bit (Bit 21) in the IRQENA register (Address 0x22C and Address 0x32C). When this interrupt is enabled, an external interrupt is issued if the CRC value changes from the value that it held at the time that it was enabled.

Table 12. Registers Included in the Checksum

| Configuration and Control Registers | | Calibration Registers | |
|-------------------------------------|-----------------|-----------------------|-----------------|
| Register Name | Address | Register Name | Address |
| LCYCMODE | 0x004 | AIGAIN | 0x280 and 0x380 |
| PGA_V | 0x007 | VGAIN | 0x281 and 0x381 |
| PGA_IA | 0x008 | AWGAIN | 0x282 and 0x382 |
| PGA_IB | 0x009 | AVARGAIN | 0x283 and 0x383 |
| CONFIG | 0x102 | AVAGAIN | 0x284 and 0x384 |
| CF1DEN | 0x103 | AIOS | 0x285 and 0x385 |
| CF2DEN | 0x104 | AIRMSOS | 0x286 and 0x386 |
| CFMODE | 0x107 | VOS | 0x287 and 0x387 |
| PHCALA | 0x108 | VRMSOS | 0x288 and 0x388 |
| PHCALB | 0x109 | AWATTOS | 0x289 and 0x389 |
| ALT_OUTPUT | 0x110 | AVAROS | 0x28A and 0x38A |
| ACCMODE | 0x201 and 0x301 | AVAOS | 0x28B and 0x38B |
| IRQENA | 0x22C and 0x32C | BIGAIN | 0x28C and 0x38C |
| IRQENB | 0x22F and 0x32F | Reserved | 0x28D and 0x38D |
| | | BWGAIN | 0x28E and 0x38E |
| | | BVARGAIN | 0x28F and 0x38F |
| | | BVAGAIN | 0x290 and 0x390 |
| | | BIOS | 0x291 and 0x391 |
| | | BIRMSOS | 0x292 and 0x392 |
| | | Reserved | 0x293 and 0x393 |
| | | Reserved | 0x294 and 0x394 |
| | | BWATTOS | 0x295 and 0x395 |
| | | BVAROS | 0x296 and 0x396 |
| | | BVAOS | 0x297 and 0x397 |

ADE7953 REGISTERS

The ADE7953 contains registers that are 8, 16, 24, and 32 bits long. All signed registers are in the two's complement format with the exception of the PHCALA and PHCALB registers, which are in sign magnitude format. The 24-bit and 32-bit registers contain the same data but can be accessed in two different register lengths. The 24-bit register option increases communication speed; the 32-bit register option provides simplicity when coding with the long format. When accessing the 32-bit registers, only the lower 24 bits contain valid data (the upper 8 bits are sign extended). A write to a 24-bit register changes the value in the corresponding 32-bit register, and vice versa. Therefore, each 24-bit/32-bit register can be thought of as one memory location that can be accessed via two different paths.

Table 13. 8-Bit Registers

| Address | Register Name | R/W | Default | Type | Register Description |
|---------|---------------|-----|---------|----------|--|
| 0x000 | SAGCYC | R/W | 0x00 | Unsigned | Sag line cycles |
| 0x001 | DISNOLOAD | R/W | 0x00 | Unsigned | No-load detection disable |
| 0x004 | LCYCMODE | R/W | 0x40 | Unsigned | Line cycle accumulation mode configuration |
| 0x007 | PGA_V | R/W | 0x00 | Unsigned | Voltage channel gain configuration (Bits[2:0]) |
| 0x008 | PGA_IA | R/W | 0x00 | Unsigned | Current Channel A gain configuration (Bits[2:0]) |
| 0x009 | PGA_IB | R/W | 0x00 | Unsigned | Current Channel B gain configuration (Bits[2:0]) |
| 0x040 | WRITE_PROTECT | R/W | 0x00 | Unsigned | Write protection bits (Bits[2:0]) |
| 0x0FD | LAST_OP | R | 0x00 | Unsigned | Contains the type (read or write) of the last successful communication (0x35 = read; 0xCA = write) |
| 0x0FF | LAST_RWDATA | R | 0x00 | Unsigned | Contains the data from the last successful 8-bit register communication |
| 0x702 | Version | R | N/A | Unsigned | Contains the silicon version number |
| 0x800 | EX_REF | R/W | 0x00 | Unsigned | Reference input configuration: set to 0 for internal; set to 1 for external |

Table 14. 16-Bit Registers

| Address | Register Name | R/W | Default | Type | Register Description |
|---------|---------------|-----|---------|----------|---|
| 0x100 | ZXTOUT | R/W | 0xFFFF | Unsigned | Zero-crossing timeout |
| 0x101 | LINECYC | R/W | 0x0000 | Unsigned | Number of half line cycles for line cycle energy accumulation mode |
| 0x102 | CONFIG | R/W | 0x8004 | Unsigned | Configuration register |
| 0x103 | CF1DEN | R/W | 0x003F | Unsigned | CF1 frequency divider denominator. When modifying this register, two sequential write operations must be performed to ensure that the write is successful. |
| 0x104 | CF2DEN | R/W | 0x003F | Unsigned | CF2 frequency divider denominator. When modifying this register, two sequential write operations must be performed to ensure that the write is successful. |
| 0x107 | CFMODE | R/W | 0x0300 | Unsigned | CF output selection |
| 0x108 | PHCALA | R/W | 0x0000 | Signed | Phase calibration register (Current Channel A). This register is in sign magnitude format. |
| 0x109 | PHCALB | R/W | 0x0000 | Signed | Phase calibration register (Current Channel B). This register is in sign magnitude format. |
| 0x10A | PFA | R | 0x0000 | Signed | Power factor (Current Channel A) |
| 0x10B | PFB | R | 0x0000 | Signed | Power factor (Current Channel B) |
| 0x10C | ANGLE_A | R | 0x0000 | Signed | Angle between the voltage input and the Current Channel A input |
| 0x10D | ANGLE_B | R | 0x0000 | Signed | Angle between the voltage input and the Current Channel B input |
| 0x10E | Period | R | 0x0000 | Unsigned | Period register |
| 0x110 | ALT_OUTPUT | R/W | 0x0000 | Unsigned | Alternative output functions |
| 0x1FE | LAST_ADD | R | 0x0000 | Unsigned | Contains the address of the last successful communication |
| 0x1FF | LAST_RWDATA | R | 0x0000 | Unsigned | Contains the data from the last successful 16-bit register communication |
| 0x120 | Reserved | R/W | 0x0000 | Unsigned | This register should be set to 30h to meet the performance specified in Table 1. To modify this register, it must be unlocked by setting Register Address 0xFE to 0xAD immediately prior. |

Table 15. 24-Bit/32-Bit Registers

| Address | | Register Name | R/W | Default | Type | Register Description |
|---------|--------|---------------|-----|------------|----------|--|
| 24-Bit | 32-Bit | | | | | |
| 0x200 | 0x300 | SAGLVL | R/W | 0x000000 | Unsigned | Sag voltage level |
| 0x201 | 0x301 | ACCMODE | R/W | 0x000000 | Unsigned | Accumulation mode |
| 0x203 | 0x303 | AP_NOLOAD | R/W | 0x00E419 | Unsigned | Active power no-load level |
| 0x204 | 0x304 | VAR_NOLOAD | R/W | 0x00E419 | Unsigned | Reactive power no-load level |
| 0x205 | 0x305 | VA_NOLOAD | R/W | 0x000000 | Unsigned | Apparent power no-load level |
| 0x210 | 0x310 | AVA | R | 0x000000 | Signed | Instantaneous apparent power (Current Channel A) |
| 0x211 | 0x311 | BVA | R | 0x000000 | Signed | Instantaneous apparent power (Current Channel B) |
| 0x212 | 0x312 | AWATT | R | 0x000000 | Signed | Instantaneous active power (Current Channel A) |
| 0x213 | 0x313 | BWATT | R | 0x000000 | Signed | Instantaneous active power (Current Channel B) |
| 0x214 | 0x314 | AVAR | R | 0x000000 | Signed | Instantaneous reactive power (Current Channel A) |
| 0x215 | 0x315 | BVAR | R | 0x000000 | Signed | Instantaneous reactive power (Current Channel B) |
| 0x216 | 0x316 | IA | R | 0x000000 | Signed | Instantaneous current (Current Channel A) |
| 0x217 | 0x317 | IB | R | 0x000000 | Signed | Instantaneous current (Current Channel B) |
| 0x218 | 0x318 | V | R | 0x000000 | Signed | Instantaneous voltage (voltage channel) |
| 0x21A | 0x31A | IRMSA | R | 0x000000 | Unsigned | IRMS register (Current Channel A) |
| 0x21B | 0x31B | IRMSB | R | 0x000000 | Unsigned | IRMS register (Current Channel B) |
| 0x21C | 0x31C | VRMS | R | 0x000000 | Unsigned | VRMS register |
| 0x21E | 0x31E | AENERGYA | R | 0x000000 | Signed | Active energy (Current Channel A) |
| 0x21F | 0x31F | AENERGYB | R | 0x000000 | Signed | Active energy (Current Channel B) |
| 0x220 | 0x320 | REENERGYA | R | 0x000000 | Signed | Reactive energy (Current Channel A) |
| 0x221 | 0x321 | REENERGYB | R | 0x000000 | Signed | Reactive energy (Current Channel B) |
| 0x222 | 0x322 | APENERGYA | R | 0x000000 | Signed | Apparent energy (Current Channel A) |
| 0x223 | 0x323 | APENERGYB | R | 0x000000 | Signed | Apparent energy (Current Channel B) |
| 0x224 | 0x324 | OVLVL | R/W | 0xFFFFFFFF | Unsigned | Overvoltage level |
| 0x225 | 0x325 | OILVL | R/W | 0xFFFFFFFF | Unsigned | Overcurrent level |
| 0x226 | 0x326 | VPEAK | R | 0x000000 | Unsigned | Voltage channel peak |
| 0x227 | 0x327 | RSTVPEAK | R | 0x000000 | Unsigned | Read voltage peak with reset |
| 0x228 | 0x328 | IAPEAK | R | 0x000000 | Unsigned | Current Channel A peak |
| 0x229 | 0x329 | RSTIAPEAK | R | 0x000000 | Unsigned | Read Current Channel A peak with reset |
| 0x22A | 0x32A | IBPEAK | R | 0x000000 | Unsigned | Current Channel B peak |
| 0x22B | 0x32B | RSTIBPEAK | R | 0x000000 | Unsigned | Read Current Channel B peak with reset |
| 0x22C | 0x32C | IRQENA | R/W | 0x100000 | Unsigned | Interrupt enable (Current Channel A) |
| 0x22D | 0x32D | IRQSTATA | R | 0x000000 | Unsigned | Interrupt status (Current Channel A) |
| 0x22E | 0x32E | RSTIRQSTATA | R | 0x000000 | Unsigned | Reset interrupt status (Current Channel A) |
| 0x22F | 0x32F | IRQENB | R/W | 0x000000 | Unsigned | Interrupt enable (Current Channel B) |
| 0x230 | 0x330 | IRQSTATB | R | 0x000000 | Unsigned | Interrupt status (Current Channel B) |
| 0x231 | 0x331 | RSTIRQSTATB | R | 0x000000 | Unsigned | Reset interrupt status (Current Channel B) |
| N/A | 0x37F | CRC | R | 0xFFFFFFFF | Unsigned | Checksum |
| 0x280 | 0x380 | AIGAIN | R/W | 0x400000 | Unsigned | Current channel gain (Current Channel A) |
| 0x281 | 0x381 | VGAIN | R/W | 0x400000 | Unsigned | Voltage channel gain |
| 0x282 | 0x382 | AWGAIN | R/W | 0x400000 | Unsigned | Active power gain (Current Channel A) |
| 0x283 | 0x383 | AVARGAIN | R/W | 0x400000 | Unsigned | Reactive power gain (Current Channel A) |
| 0x284 | 0x384 | AVAGAIN | R/W | 0x400000 | Unsigned | Apparent power gain (Current Channel A) |
| 0x285 | 0x385 | Reserved | R/W | 0x000000 | Signed | This register should not be modified. |
| 0x286 | 0x386 | AIRMSOS | R/W | 0x000000 | Signed | IRMS offset (Current Channel A) |
| 0x287 | 0x387 | Reserved | R/W | 0x000000 | Signed | This register should not be modified. |
| 0x288 | 0x388 | VRMSOS | R/W | 0x000000 | Signed | VRMS offset |
| 0x289 | 0x389 | AWATTOS | R/W | 0x000000 | Signed | Active power offset correction (Current Channel A) |
| 0x28A | 0x38A | AVAROS | R/W | 0x000000 | Signed | Reactive power offset correction (Current Channel A) |
| 0x28B | 0x38B | AVEOS | R/W | 0x000000 | Signed | Apparent power offset correction (Current Channel A) |

| Address | | Register Name | R/W | Default | Type | Register Description |
|---------|--------|---------------|-----|----------|----------|---|
| 24-Bit | 32-Bit | | | | | |
| 0x28C | 0x38C | BIGAIN | R/W | 0x400000 | Unsigned | Current channel gain (Current Channel B) |
| 0x28D | 0x38D | Reserved | R/W | 0x400000 | Unsigned | This register should not be modified. |
| 0x28E | 0x38E | BWGAIN | R/W | 0x400000 | Unsigned | Active power gain (Current Channel B) |
| 0x28F | 0x38F | BVARGAIN | R/W | 0x400000 | Unsigned | Reactive power gain (Current Channel B) |
| 0x290 | 0x390 | BVAGAIN | R/W | 0x400000 | Unsigned | Apparent power gain (Current Channel B) |
| 0x291 | 0x391 | Reserved | R/W | 0x000000 | Signed | This register should not be modified. |
| 0x292 | 0x392 | BIRMSOS | R/W | 0x000000 | Signed | IRMS offset (Current Channel B) |
| 0x293 | 0x393 | Reserved | R/W | 0x000000 | Unsigned | This register should not be modified. |
| 0x294 | 0x394 | Reserved | R/W | 0x000000 | Unsigned | This register should not be modified. |
| 0x295 | 0x395 | BWATTOS | R/W | 0x000000 | Signed | Active power offset correction (Current Channel B) |
| 0x296 | 0x396 | BVAROS | R/W | 0x000000 | Signed | Reactive power offset correction (Current Channel B) |
| 0x297 | 0x397 | BVAOS | R/W | 0x000000 | Signed | Apparent power offset correction (Current Channel B) |
| 0x2FF | 0x3FF | LAST_RWDATA | R | 0x000000 | Unsigned | Contains the data from the last successful 24-bit/32-bit register communication |

ADE7953 REGISTER DESCRIPTIONS

Table 16. DISNOLOAD Register (Address 0x001)

| Bits | Bit Name | Default | Description |
|------|--------------|---------|---|
| 0 | DIS_APNLOAD | 0 | 1 = disable the active power no-load feature on Current Channel A and Current Channel B |
| 1 | DIS_VARNLOAD | 0 | 1 = disable the reactive power no-load feature on Current Channel A and Current Channel B |
| 2 | DIS_VANLOAD | 0 | 1 = disable the apparent power no-load feature on Current Channel A and Current Channel B |

Table 17. LCYCMODE Register (Address 0x004)

| Bits | Bit Name | Default | Description |
|------|----------|---------|---|
| 0 | ALWATT | 0 | 0 = disable active energy line cycle accumulation mode on Current Channel A 1 = enable active energy line cycle accumulation mode on Current Channel A |
| 1 | BLWATT | 0 | 0 = disable active energy line cycle accumulation mode on Current Channel B 1 = enable active energy line cycle accumulation mode on Current Channel B |
| 2 | ALVAR | 0 | 0 = disable reactive energy line cycle accumulation mode on Current Channel A 1 = enable reactive energy line cycle accumulation mode on Current Channel A |
| 3 | BLVAR | 0 | 0 = disable reactive energy line cycle accumulation mode on Current Channel B 1 = enable reactive energy line cycle accumulation mode on Current Channel B |
| 4 | ALVA | 0 | 0 = disable apparent energy line cycle accumulation mode on Current Channel A 1 = enable apparent energy line cycle accumulation mode on Current Channel A |
| 5 | BLVA | 0 | 0 = disable apparent energy line cycle accumulation mode on Current Channel B 1 = enable apparent energy line cycle accumulation mode on Current Channel B |
| 6 | RSTREAD | 1 | 0 = disable read with reset for all registers 1 = enable read with reset for all registers |

Table 18. CONFIG Register (Address 0x102)

| Bits | Bit Name | Default | Description |
|------|------------|---------|---|
| 0 | INTENA | 0 | 1 = integrator enable (Current Channel A) |
| 1 | INTENB | 0 | 1 = integrator enable (Current Channel B) |
| 2 | HPFEN | 1 | 1 = HPF enable (all channels) |
| 3 | PFMODE | 0 | 0 = power factor is based on instantaneous powers 1 = power factor is based on line cycle accumulation mode energies |
| 4 | REVP_CF | 0 | 0 = REVP is updated on CF1 1 = REVP is updated on CF2 |
| 5 | REVP_PULSE | 0 | 0 = REVP is high when reverse polarity is true, low when reverse polarity is false 1 = REVP outputs a 1 Hz pulse when reverse polarity is true and is low when reverse polarity is false |
| 6 | ZXLPF | 0 | 0 = ZX LPF is enabled 1 = ZX LPF is disabled |
| 7 | SWRST | 0 | Setting this bit enables a software reset |

| Bits | Bit Name | Default | Description | | | | | | | | | | |
|---------|---|---------|---|---------|----------------|----|---|----|---|----|---|----|---|
| 8 | CRC_ENABLE | 0 | 0 = CRC is disabled 1 = CRC is enabled | | | | | | | | | | |
| [10:9] | PWR_LPF_SEL | 00 | Low-pass filter options | | | | | | | | | | |
| | | | <table border="1"> <thead> <tr> <th>Setting</th> <th>Filtering</th> </tr> </thead> <tbody> <tr> <td>00</td> <td>~250 ms</td> </tr> <tr> <td>01</td> <td>~500 ms</td> </tr> <tr> <td>10</td> <td>~1 sec</td> </tr> <tr> <td>11</td> <td>~2 sec</td> </tr> </tbody> </table> | Setting | Filtering | 00 | ~250 ms | 01 | ~500 ms | 10 | ~1 sec | 11 | ~2 sec |
| Setting | Filtering | | | | | | | | | | | | |
| 00 | ~250 ms | | | | | | | | | | | | |
| 01 | ~500 ms | | | | | | | | | | | | |
| 10 | ~1 sec | | | | | | | | | | | | |
| 11 | ~2 sec | | | | | | | | | | | | |
| 11 | ZX_I | 0 | 0 = ZX_I is based on Current Channel A 1 = ZX_I is based on Current Channel B | | | | | | | | | | |
| [13:12] | ZX_EDGE | 00 | Zero-crossing interrupt edge selection | | | | | | | | | | |
| | | | <table border="1"> <thead> <tr> <th>Setting</th> <th>Edge Selection</th> </tr> </thead> <tbody> <tr> <td>00</td> <td>Interrupt is issued on both positive-going and negative-going zero crossing</td> </tr> <tr> <td>01</td> <td>Interrupt is issued on negative-going zero crossing</td> </tr> <tr> <td>10</td> <td>Interrupt is issued on positive-going zero crossing</td> </tr> <tr> <td>11</td> <td>Interrupt is issued on both positive-going and negative-going zero crossing</td> </tr> </tbody> </table> | Setting | Edge Selection | 00 | Interrupt is issued on both positive-going and negative-going zero crossing | 01 | Interrupt is issued on negative-going zero crossing | 10 | Interrupt is issued on positive-going zero crossing | 11 | Interrupt is issued on both positive-going and negative-going zero crossing |
| Setting | Edge Selection | | | | | | | | | | | | |
| 00 | Interrupt is issued on both positive-going and negative-going zero crossing | | | | | | | | | | | | |
| 01 | Interrupt is issued on negative-going zero crossing | | | | | | | | | | | | |
| 10 | Interrupt is issued on positive-going zero crossing | | | | | | | | | | | | |
| 11 | Interrupt is issued on both positive-going and negative-going zero crossing | | | | | | | | | | | | |
| 14 | Reserved | 0 | Reserved | | | | | | | | | | |
| 15 | COMM_LOCK | 1 | 0 = communication locking feature is enabled 1 = communication locking feature is disabled | | | | | | | | | | |

Table 19. CFMODE Register (Address 0x107)

| Bits | Bit Name | Default | Description | | | | | | | | | | | | | | | | | | | | | | |
|---------|--|---------|--|---------|---------------------------------|------|---|------|---|------|---|------|---|------|---|------|---|------|---|------|---|------|--|------|--|
| [3:0] | CF1SEL | 0000 | Configuration of output signal on CF1 pin | | | | | | | | | | | | | | | | | | | | | | |
| | | | <table border="1"> <thead> <tr> <th>Setting</th> <th>CF1 Output Signal Configuration</th> </tr> </thead> <tbody> <tr> <td>0000</td> <td>CF1 is proportional to active power (Current Channel A)</td> </tr> <tr> <td>0001</td> <td>CF1 is proportional to reactive power (Current Channel A)</td> </tr> <tr> <td>0010</td> <td>CF1 is proportional to apparent power (Current Channel A)</td> </tr> <tr> <td>0011</td> <td>CF1 is proportional to IRMS (Current Channel A)</td> </tr> <tr> <td>0100</td> <td>CF1 is proportional to active power (Current Channel B)</td> </tr> <tr> <td>0101</td> <td>CF1 is proportional to reactive power (Current Channel B)</td> </tr> <tr> <td>0110</td> <td>CF1 is proportional to apparent power (Current Channel B)</td> </tr> <tr> <td>0111</td> <td>CF1 is proportional to IRMS (Current Channel B)</td> </tr> <tr> <td>1000</td> <td>CF1 is proportional to IRMS (Current Channel A) + IRMS (Current Channel B)</td> </tr> <tr> <td>1001</td> <td>CF1 is proportional to active power (Current Channel A) + active power (Current Channel B)</td> </tr> </tbody> </table> | Setting | CF1 Output Signal Configuration | 0000 | CF1 is proportional to active power (Current Channel A) | 0001 | CF1 is proportional to reactive power (Current Channel A) | 0010 | CF1 is proportional to apparent power (Current Channel A) | 0011 | CF1 is proportional to IRMS (Current Channel A) | 0100 | CF1 is proportional to active power (Current Channel B) | 0101 | CF1 is proportional to reactive power (Current Channel B) | 0110 | CF1 is proportional to apparent power (Current Channel B) | 0111 | CF1 is proportional to IRMS (Current Channel B) | 1000 | CF1 is proportional to IRMS (Current Channel A) + IRMS (Current Channel B) | 1001 | CF1 is proportional to active power (Current Channel A) + active power (Current Channel B) |
| Setting | CF1 Output Signal Configuration | | | | | | | | | | | | | | | | | | | | | | | | |
| 0000 | CF1 is proportional to active power (Current Channel A) | | | | | | | | | | | | | | | | | | | | | | | | |
| 0001 | CF1 is proportional to reactive power (Current Channel A) | | | | | | | | | | | | | | | | | | | | | | | | |
| 0010 | CF1 is proportional to apparent power (Current Channel A) | | | | | | | | | | | | | | | | | | | | | | | | |
| 0011 | CF1 is proportional to IRMS (Current Channel A) | | | | | | | | | | | | | | | | | | | | | | | | |
| 0100 | CF1 is proportional to active power (Current Channel B) | | | | | | | | | | | | | | | | | | | | | | | | |
| 0101 | CF1 is proportional to reactive power (Current Channel B) | | | | | | | | | | | | | | | | | | | | | | | | |
| 0110 | CF1 is proportional to apparent power (Current Channel B) | | | | | | | | | | | | | | | | | | | | | | | | |
| 0111 | CF1 is proportional to IRMS (Current Channel B) | | | | | | | | | | | | | | | | | | | | | | | | |
| 1000 | CF1 is proportional to IRMS (Current Channel A) + IRMS (Current Channel B) | | | | | | | | | | | | | | | | | | | | | | | | |
| 1001 | CF1 is proportional to active power (Current Channel A) + active power (Current Channel B) | | | | | | | | | | | | | | | | | | | | | | | | |
| [7:4] | CF2SEL | 0000 | Configuration of output signal on CF2 pin | | | | | | | | | | | | | | | | | | | | | | |
| | | | <table border="1"> <thead> <tr> <th>Setting</th> <th>CF2 Output Signal Configuration</th> </tr> </thead> <tbody> <tr> <td>0000</td> <td>CF2 is proportional to active power (Current Channel A)</td> </tr> <tr> <td>0001</td> <td>CF2 is proportional to reactive power (Current Channel A)</td> </tr> <tr> <td>0010</td> <td>CF2 is proportional to apparent power (Current Channel A)</td> </tr> <tr> <td>0011</td> <td>CF2 is proportional to IRMS (Current Channel A)</td> </tr> <tr> <td>0100</td> <td>CF2 is proportional to active power (Current Channel B)</td> </tr> <tr> <td>0101</td> <td>CF2 is proportional to reactive power (Current Channel B)</td> </tr> <tr> <td>0110</td> <td>CF2 is proportional to apparent power (Current Channel B)</td> </tr> <tr> <td>0111</td> <td>CF2 is proportional to IRMS (Current Channel B)</td> </tr> <tr> <td>1000</td> <td>CF2 is proportional to IRMS (Current Channel A) + IRMS (Current Channel B)</td> </tr> <tr> <td>1001</td> <td>CF2 is proportional to active power (Current Channel A) + active power (Current Channel B)</td> </tr> </tbody> </table> | Setting | CF2 Output Signal Configuration | 0000 | CF2 is proportional to active power (Current Channel A) | 0001 | CF2 is proportional to reactive power (Current Channel A) | 0010 | CF2 is proportional to apparent power (Current Channel A) | 0011 | CF2 is proportional to IRMS (Current Channel A) | 0100 | CF2 is proportional to active power (Current Channel B) | 0101 | CF2 is proportional to reactive power (Current Channel B) | 0110 | CF2 is proportional to apparent power (Current Channel B) | 0111 | CF2 is proportional to IRMS (Current Channel B) | 1000 | CF2 is proportional to IRMS (Current Channel A) + IRMS (Current Channel B) | 1001 | CF2 is proportional to active power (Current Channel A) + active power (Current Channel B) |
| Setting | CF2 Output Signal Configuration | | | | | | | | | | | | | | | | | | | | | | | | |
| 0000 | CF2 is proportional to active power (Current Channel A) | | | | | | | | | | | | | | | | | | | | | | | | |
| 0001 | CF2 is proportional to reactive power (Current Channel A) | | | | | | | | | | | | | | | | | | | | | | | | |
| 0010 | CF2 is proportional to apparent power (Current Channel A) | | | | | | | | | | | | | | | | | | | | | | | | |
| 0011 | CF2 is proportional to IRMS (Current Channel A) | | | | | | | | | | | | | | | | | | | | | | | | |
| 0100 | CF2 is proportional to active power (Current Channel B) | | | | | | | | | | | | | | | | | | | | | | | | |
| 0101 | CF2 is proportional to reactive power (Current Channel B) | | | | | | | | | | | | | | | | | | | | | | | | |
| 0110 | CF2 is proportional to apparent power (Current Channel B) | | | | | | | | | | | | | | | | | | | | | | | | |
| 0111 | CF2 is proportional to IRMS (Current Channel B) | | | | | | | | | | | | | | | | | | | | | | | | |
| 1000 | CF2 is proportional to IRMS (Current Channel A) + IRMS (Current Channel B) | | | | | | | | | | | | | | | | | | | | | | | | |
| 1001 | CF2 is proportional to active power (Current Channel A) + active power (Current Channel B) | | | | | | | | | | | | | | | | | | | | | | | | |
| 8 | CF1DIS | 1 | 0 = CF1 output is enabled 1 = CF1 output is disabled | | | | | | | | | | | | | | | | | | | | | | |
| 9 | CF2DIS | 1 | 0 = CF2 output is enabled 1 = CF2 output is disabled | | | | | | | | | | | | | | | | | | | | | | |

Table 20. ALT_OUTPUT Register (Address 0x110)

| Bits | Bit Name | Default | Description | |
|--------|--|---------|------------------------------------|--|
| [3:0] | ZX_ALT | 0000 | Configuration of ZX pin (Pin 1) | |
| | | | Setting | ZX Pin Configuration |
| | | | 0000 | ZX detection is output on Pin 1 (default) |
| | | | 0001 | Sag detection is output on Pin 1 |
| | | | 0010 | Reserved |
| | | | 0011 | Reserved |
| | | | 0100 | Reserved |
| | | | 0101 | Active power no-load detection (Current Channel A) is output on Pin 1 |
| | | | 0110 | Active power no-load detection (Current Channel B) is output on Pin 1 |
| | | | 0111 | Reactive power no-load detection (Current Channel A) is output on Pin 1 |
| | | | 1000 | Reactive power no-load detection (Current Channel B) is output on Pin 1 |
| | | | 1001 | Unlatched waveform sampling signal is output on Pin 1 |
| | | | 1010 | $\overline{\text{IRQ}}$ signal is output on Pin 1 |
| | | | 1011 | ZX_I detection is output on Pin 1 |
| 1100 | $\overline{\text{REVP}}$ detection is output on Pin 1 | | | |
| 1101 | Reserved (set to default value) | | | |
| 111x | Reserved (set to default value) | | | |
| [7:4] | ZXI_ALT | 0000 | Configuration of ZX_I pin (Pin 21) | |
| | | | Setting | ZX_I Pin Configuration |
| | | | 0000 | ZX_I detection is output on Pin 21 (default) |
| | | | 0001 | Sag detection is output on Pin 21 |
| | | | 0010 | Reserved |
| | | | 0011 | Reserved |
| | | | 0100 | Reserved |
| | | | 0101 | Active power no-load detection (Current Channel A) is output on Pin 21 |
| | | | 0110 | Active power no-load detection (Current Channel B) is output on Pin 21 |
| | | | 0111 | Reactive power no-load detection (Current Channel A) is output on Pin 21 |
| | | | 1000 | Reactive power no-load detection (Current Channel B) is output on Pin 21 |
| | | | 1001 | Unlatched waveform sampling signal is output on Pin 21 |
| | | | 1010 | $\overline{\text{IRQ}}$ signal is output on Pin 21 |
| | | | 1011 | ZX detection is output on Pin 21 |
| 1100 | $\overline{\text{REVP}}$ detection is output on Pin 21 | | | |
| 1101 | Reserved (set to default value) | | | |
| 111x | Reserved (set to default value) | | | |
| [11:8] | REVP_ALT | 0000 | Configuration of REVP pin (Pin 20) | |
| | | | Setting | REVP Pin Configuration |
| | | | 0000 | $\overline{\text{REVP}}$ detection is output on Pin 20 (default) |
| | | | 0001 | Sag detection is output on Pin 20 |
| | | | 0010 | Reserved |
| | | | 0011 | Reserved |
| | | | 0100 | Reserved |
| | | | 0101 | Active power no-load detection (Current Channel A) is output on Pin 20 |
| | | | 0110 | Active power no-load detection (Current Channel B) is output on Pin 20 |
| | | | 0111 | Reactive power no-load detection (Current Channel A) is output on Pin 20 |
| | | | 1000 | Reactive power no-load detection (Current Channel B) is output on Pin 20 |
| | | | 1001 | Unlatched waveform sampling signal is output on Pin 20 |
| | | | 1010 | $\overline{\text{IRQ}}$ signal is output on Pin 20 |
| | | | 1011 | ZX detection is output on Pin 20 |
| 1100 | ZX_I detection is output on Pin 20 | | | |
| 1101 | Reserved (set to default value) | | | |
| 111x | Reserved (set to default value) | | | |

Table 21. ACCMODE Register (Address 0x201 and Address 0x301)

| Bits | Bit Name | Default | Description | |
|---------|------------|---------|--|--|
| [1:0] | AWATTACC | 00 | Current Channel A active energy accumulation mode | |
| | | | Setting | Active Energy Accumulation Mode (Current Channel A) |
| | | | 00 | Normal mode |
| | | | 01 | Positive-only accumulation mode |
| | | | 10 | Absolute accumulation mode |
| | | | 11 | Reserved |
| [3:2] | BWATTACC | 00 | Current Channel B active energy accumulation mode | |
| | | | Setting | Active Energy Accumulation Mode (Current Channel B) |
| | | | 00 | Normal mode |
| | | | 01 | Positive-only accumulation mode |
| | | | 10 | Absolute accumulation mode |
| | | | 11 | Reserved |
| [5:4] | AVARACC | 00 | Current Channel A reactive energy accumulation mode | |
| | | | Setting | Reactive Energy Accumulation Mode (Current Channel A) |
| | | | 00 | Normal mode |
| | | | 01 | Antitamper accumulation mode |
| | | | 10 | Absolute accumulation mode |
| | | | 11 | Reserved |
| [7:6] | BVARACC | 00 | Current Channel B reactive energy accumulation mode | |
| | | | Setting | Reactive Energy Accumulation Mode (Current Channel B) |
| | | | 00 | Normal mode |
| | | | 01 | Antitamper accumulation mode |
| | | | 10 | Absolute accumulation mode |
| | | | 11 | Reserved |
| 8 | AVAACC | 0 | 0 = Current Channel A apparent energy accumulation is in normal mode 1 = Current Channel A apparent energy accumulation is based on IRMSA | |
| 9 | BVAACC | 0 | 0 = Current Channel B apparent energy accumulation is in normal mode 1 = Current Channel B apparent energy accumulation is based on IRMSB | |
| 10 | APSIGN_A | 0 | 0 = active power on Current Channel A is positive 1 = active power on Current Channel A is negative | |
| 11 | APSIGN_B | 0 | 0 = active power on Current Channel B is positive 1 = active power on Current Channel B is negative | |
| 12 | VARSIGN_A | 0 | 0 = reactive power on Current Channel A is positive 1 = reactive power on Current Channel A is negative | |
| 13 | VARSIGN_B | 0 | 0 = reactive power on Current Channel B is positive 1 = reactive power on Current Channel B is negative | |
| [15:14] | Reserved | 00 | Reserved | |
| 16 | ACTNLOAD_A | 0 | 0 = Current Channel A active energy is out of no-load condition 1 = Current Channel A active energy is in no-load condition | |
| 17 | VANLOAD_A | 0 | 0 = Current Channel A apparent energy is out of no-load condition 1 = Current Channel A apparent energy is in no-load condition | |
| 18 | VARNLOAD_A | 0 | 0 = Current Channel A reactive energy is out of no-load condition 1 = Current Channel A reactive energy is in no-load condition | |
| 19 | ACTNLOAD_B | 0 | 0 = Current Channel B active energy is out of no-load condition 1 = Current Channel B active energy is in no-load condition | |
| 20 | VANLOAD_B | 0 | 0 = Current Channel B apparent energy is out of no-load condition 1 = Current Channel B apparent energy is in no-load condition | |
| 21 | VARNLOAD_B | 0 | 0 = Current Channel B reactive energy is out of no-load condition 1 = Current Channel B reactive energy is in no-load condition | |

Interrupt Enable and Interrupt Status Registers

Current Channel A and Voltage Channel Registers

Table 22. IRQENA Register (Address 0x22C and Address 0x32C)

| Bits | Bit Name | Description |
|------|-------------|---|
| 0 | AEHFA | Set to 1 to enable an interrupt when the active energy is half full (Current Channel A) |
| 1 | VAREHFA | Set to 1 to enable an interrupt when the reactive energy is half full (Current Channel A) |
| 2 | VAEHFA | Set to 1 to enable an interrupt when the apparent energy is half full (Current Channel A) |
| 3 | AEOFA | Set to 1 to enable an interrupt when the active energy has overflowed or underflowed (Current Channel A) |
| 4 | VAREOFA | Set to 1 to enable an interrupt when the reactive energy has overflowed or underflowed (Current Channel A) |
| 5 | VAEOFA | Set to 1 to enable an interrupt when the apparent energy has overflowed or underflowed (Current Channel A) |
| 6 | AP_NOLOADA | Set to 1 to enable an interrupt when the active power no-load condition is detected on Current Channel A |
| 7 | VAR_NOLOADA | Set to 1 to enable an interrupt when the reactive power no-load condition is detected on Current Channel A |
| 8 | VA_NOLOADA | Set to 1 to enable an interrupt when the apparent power no-load condition is detected on Current Channel A |
| 9 | APSIGN_A | Set to 1 to enable an interrupt when the sign of active energy has changed (Current Channel A) |
| 10 | VARSIGN_A | Set to 1 to enable an interrupt when the sign of reactive energy has changed (Current Channel A) |
| 11 | ZXTO_IA | Set to 1 to enable an interrupt when the zero crossing has been missing on Current Channel A for the length of time specified in the ZXTOOUT register |
| 12 | ZXIA | Set to 1 to enable an interrupt when the current Channel A zero crossing occurs |
| 13 | OIA | Set to 1 to enable an interrupt when the current Channel A peak has exceeded the overcurrent threshold set in the OILVL register |
| 14 | ZXTO | Set to 1 to enable an interrupt when a zero crossing has been missing on the voltage channel for the length of time specified in the ZXTOOUT register |
| 15 | ZXV | Set to 1 to enable an interrupt when the voltage channel zero crossing occurs |
| 16 | OV | Set to 1 to enable an interrupt when the voltage peak has exceeded the overvoltage threshold set in the OVLVL register |
| 17 | WSMP | Set to 1 to enable an interrupt when new waveform data is acquired |
| 18 | CYCEND | Set to 1 to enable an interrupt when it is the end of a line cycle accumulation period |
| 19 | Sag | Set to 1 to enable an interrupt when a sag event has occurred |
| 20 | Reset | This interrupt is always enabled and cannot be disabled |
| 21 | CRC | Set to 1 to enable an interrupt when the checksum has changed |

Table 23. IRQSTATA Register (Address 0x22D and Address 0x32D) and RSTIRQSTATA Register (Address 0x22E and Address 0x32E)

| Bits | Bit Name | Description |
|------|-------------|--|
| 0 | AEHFA | Set to 1 when the active energy register is half full (Current Channel A) |
| 1 | VAREHFA | Set to 1 when the reactive energy register is half full (Current Channel A) |
| 2 | VAEHFA | Set to 1 when the apparent energy register is half full (Current Channel A) |
| 3 | AEOFA | Set to 1 when the active energy register has overflowed or underflowed (Current Channel A) |
| 4 | VAREOFA | Set to 1 when the reactive energy register has overflowed or underflowed (Current Channel A) |
| 5 | VAEOFA | Set to 1 when the apparent energy register has overflowed or underflowed (Current Channel A) |
| 6 | AP_NOLOADA | Set to 1 when the active power no-load condition is detected Current Channel A |
| 7 | VAR_NOLOADA | Set to 1 when the reactive power no-load condition is detected Current Channel A |
| 8 | VA_NOLOADA | Set to 1 when the apparent power no-load condition is detected Current Channel A |
| 9 | APSIGN_A | Set to 1 when the sign of active energy has changed (Current Channel A) |
| 10 | VARSIGN_A | Set to 1 when the sign of reactive energy has changed (Current Channel A) |
| 11 | ZXTO_IA | Set to 1 when a zero crossing has been missing on Current Channel A for the length of time specified in the ZXTOOUT register |
| 12 | ZXIA | Set to 1 when a current Channel A zero crossing is detected |
| 13 | OIA | Set to 1 when the current Channel A peak has exceeded the overcurrent threshold set in the OILVL register |
| 14 | ZXTO | Set to 1 when a zero crossing has been missing on the voltage channel for the length of time specified in the ZXTOOUT register |
| 15 | ZXV | Set to 1 when the voltage channel zero crossing is detected |
| 16 | OV | Set to 1 when the voltage peak has exceeded the overvoltage threshold set in the OVLVL register |

| Bits | Bit Name | Description |
|------|----------|---|
| 17 | WSMP | Set to 1 when new waveform data is acquired |
| 18 | CYCEND | Set to 1 at the end of a line cycle accumulation period |
| 19 | Sag | Set to 1 when a sag event has occurred |
| 20 | Reset | Set to 1 at the end of a software or hardware reset |
| 21 | CRC | Set to 1 when the checksum has changed |

Current Channel B Registers

Table 24. IRQENB Register (Address 0x22F and Address 0x32F)

| Bits | Bit Name | Description |
|------|-------------|---|
| 0 | AEHFB | Set to 1 to enable an interrupt when the active energy is half full (Current Channel B) |
| 1 | VAREHFB | Set to 1 to enable an interrupt when the reactive energy is half full (Current Channel B) |
| 2 | VAEHFB | Set to 1 to enable an interrupt when the apparent energy is half full (Current Channel B) |
| 3 | AEOFB | Set to 1 to enable an interrupt when the active energy has overflowed or underflowed (Current Channel B) |
| 4 | VAREOFB | Set to 1 to enable an interrupt when the reactive energy has overflowed or underflowed (Current Channel B) |
| 5 | VAEOFB | Set to 1 to enable an interrupt when the apparent energy has overflowed or underflowed (Current Channel B) |
| 6 | AP_NOLOADB | Set to 1 to enable an interrupt when the active power no-load detection on Current Channel B occurs |
| 7 | VAR_NOLOADB | Set to 1 to enable an interrupt when the reactive power no-load detection on Current Channel B occurs |
| 8 | VA_NOLOADB | Set to 1 to enable an interrupt when the apparent power no-load detection on Current Channel B occurs |
| 9 | APSIGN_B | Set to 1 to enable an interrupt when the sign of active energy has changed (Current Channel B) |
| 10 | VARSIGN_B | Set to 1 to enable an interrupt when the sign of reactive energy has changed (Current Channel B) |
| 11 | ZXTO_IB | Set to 1 to enable an interrupt when a zero crossing has been missing on Current Channel B for the length of time specified in the ZXTOU register |
| 12 | ZXIB | Set to 1 to enable an interrupt when the current Channel B zero crossing occurs |
| 13 | OIB | Set to 1 to enable an interrupt when the current Channel B peak has exceeded the overcurrent threshold set in the OILVL register |

Table 25. IRQSTATB Register (Address 0x230 and Address 0x330) and RSTIRQSTATB Register (Address 0x231 and Address 0x331)

| Bits | Bit Name | Description |
|------|-------------|--|
| 0 | AEHFB | Set to 1 when the active energy register is half full (Current Channel B) |
| 1 | VAREHFB | Set to 1 when the reactive energy register is half full (Current Channel B) |
| 2 | VAEHFB | Set to 1 when the apparent energy register is half full (Current Channel B) |
| 3 | AEOFB | Set to 1 when the active energy register has overflowed or underflowed (Current Channel B) |
| 4 | VAREOFB | Set to 1 when the reactive energy register has overflowed or underflowed (Current Channel B) |
| 5 | VAEOFB | Set to 1 when the apparent energy register has overflowed or underflowed (Current Channel B) |
| 6 | AP_NOLOADB | Set to 1 when the active power no-load condition is detected on Current Channel B |
| 7 | VAR_NOLOADB | Set to 1 when the reactive power no-load condition is detected on Current Channel B |
| 8 | VA_NOLOADB | Set to 1 when the apparent power no-load condition is detected on Current Channel B |
| 9 | APSIGN_B | Set to 1 when the sign of active energy has changed (Current Channel B) |
| 10 | VARSIGN_B | Set to 1 when the sign of reactive energy has changed (Current Channel B) |
| 11 | ZXTO_IB | Set to 1 when a zero crossing has been missing on Current Channel B for the length of time specified in the ZXTOU register |
| 12 | ZXIB | Set to 1 when a current Channel B zero crossing is obtained |
| 13 | OIB | Set to 1 when current Channel B peak has exceeded the overcurrent threshold set in the OILVL register |

OUTLINE DIMENSIONS

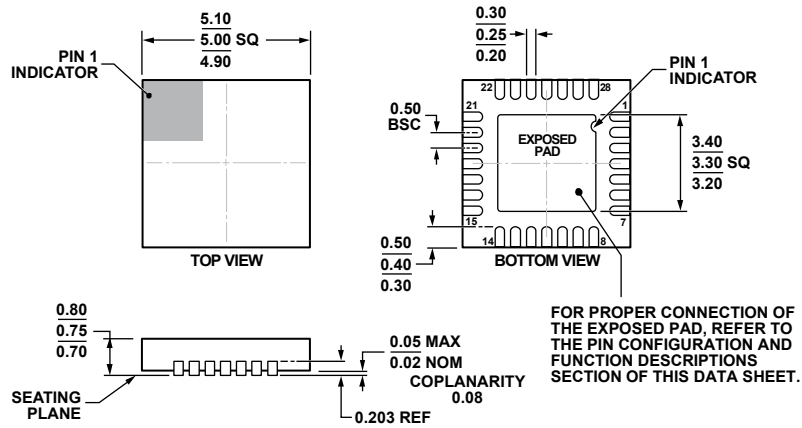

COMPLIANT TO JEDEC STANDARDS MO-220-WHHD-3.

Figure 77. 28-Lead Lead Frame Chip Scale Package [LFCSP_WQ]
 5 mm × 5 mm Body, Very Very Thin Quad
 (CP-28-6)
 Dimensions shown in millimeters

120909-A

ORDERING GUIDE

| Model ¹ | Temperature Range | Package Description | Package Option |
|--------------------|-------------------|-------------------------------------|----------------|
| ADE7953ACPZ | -40°C to +85°C | 28-Lead LFCSP_WQ | CP-28-6 |
| ADE7953ACPZ-RL | -40°C to +85°C | 28-Lead LFCSP_WQ, 13" Tape and Reel | CP-28-6 |
| EVAL-ADE7953EBZ | | Evaluation Board | |

¹ Z = RoHS Compliant Part.

I²C refers to a communications protocol originally developed by Philips Semiconductors (now NXP Semiconductors).